

SCAG[®]

POWER EQUIPMENT

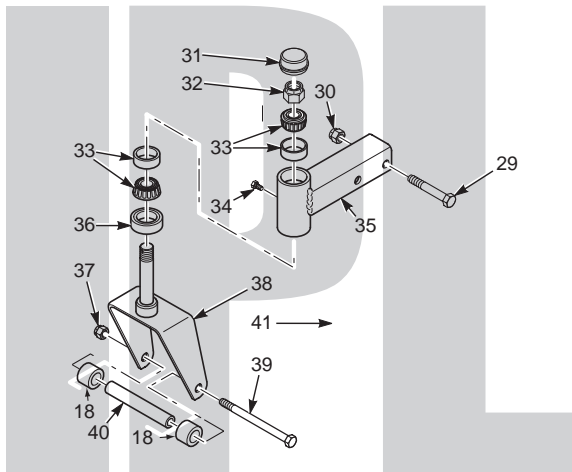

ILLUSTRATED PARTS MANUAL



Model SW Walk-Behind

THIS MANUAL CONTAINS THE ILLUSTRATED PARTS LIST FOR MODELS:

SW32-16FS

SW36A-16FS

SW36A-16FS-LE

SW48V-16FS

SW52V-18FS

with a serial number of F1200001 to F1299999

with a serial number of F1300001 to F1399999

with a serial number of F1400001 to F1499999

with a serial number of F1500001 to F1599999

with a serial number of F1600001 to F1699999

Table of Contents

32" & 36A CUTTER DECKS	2
48V & 52V CUTTER DECKS	4
NOTES.....	6
CASTER ASSEMBLY.....	7
ENGINE DECK.....	8
HANDLE ASSEMBLY.....	10
SW FUEL SYSTEM - EPA PHASE 2	12
SW FUEL SYSTEM - EPA PHASE 3	14
SW FUEL SYSTEM - C.A.R.B. TEIR 3.....	16
INSTRUMENT PANEL.....	18
PEERLESS TRANSMISSION 700-070	19
WIRE HARNESSSES	20
NOTES.....	21
REPLACEMENT DECALS AND INFORMATION PLATES	22

32" & 36A CUTTER DECKS

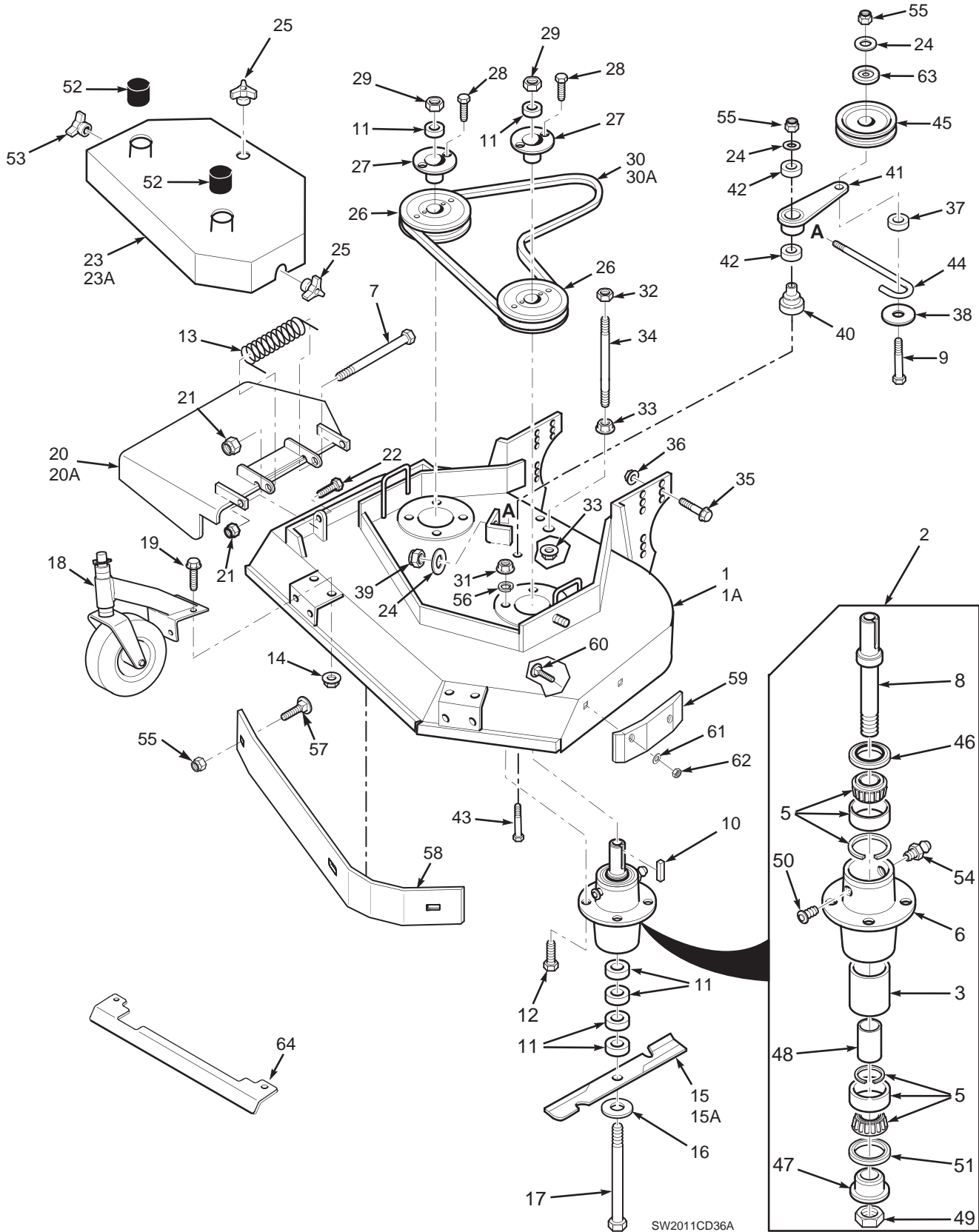

32" & 36A CUTTER DECKS

Ref. No.	Part No.	Description	32	36
1	461847	Cutter Deck w/Decals	x	
1A	461848	Cutter Deck w/Decals		x
2	461663	Cutter Spindle Assembly	x	x
3	43312	Spacer, Outside	x	x
5	481022	Bearing, Tapered	x	x
6	43644	Spindle Housing	x	x
7	04001-154	Bolt, 5/16-18 x 4-3/4"	x	x
8	43589	Spindle Shaft	x	x
9	04001-51	Bolt, 3/8-16 x 3-3/4" Hex Head	x	x
10	04063-08	Key, 1/4 x 1/4 x 2"	x	x
11	43592	Spacer, Cutter Blade - Small	x	x
12	04001-175	Bolt, 5/16-18 x 1-1/2" Hex Head Grade 8	x	x
13	482245	Spring, Chute Return	x	x
14	04019-03	Nut 5/16-18 Serrated Flange	x	x
15	481706	Cutter Blade, 16-1/2"	x	
	481707	Cutter Blade, 18"		x
15A	481710	Cutter Blade 16-1/2 Hi-Lift	x	
	481711	Cutter Blade, 18 Hi-Lift		x
16	04043-06	Flatwasher, 5/8 W	x	x
17	04001-41	Hex Hd. Bolt, 5/8-11 x 9-1/2"	x	x
18	461023	Caster Assembly	x	x
19	04017-16	Cpscrw, 5/16-18 x 3/4" Ser. Fig. Hex Head	x	x
20	461291	Discharge Chute	x	
20A	461295	Discharge Chute		x
21	04021-10	Hex Nut, 5/16-18 Elastic Stop	x	x
22	04001-09	Hex Hd Bolt, 5/16-18 x 1"	x	x
23	461709	Belt Cover Assy (Incl. Decal)	x	
23A	461413	Belt Cover Assy (Incl. Decal)		x
24	04043-04	Flat Washer, 3/8" Special	x	x
25	04029-03	Wing Nut, 3/8-16	x	x
26	482744	Pulley	x	x
27	48926	Tapered Hub	x	x
28	04001-172	Hex Hd. Bolt, 1/4-20 x 1"	x	x
29	04020-09	Hex Nut, 5/8-11	x	x
30	48278	Belt, Blade Drive	x	
30A	48204	Belt, Blade Drive		x
31	04021-22	Elastic Stop Nut, 5/16-18 Grade 8	x	x
32	04021-05	Hex Nut, 3/8-16 Center Locknut	x	x
33	04019-04	Nut, 3/8-16 Serrated Flange	x	x
34	04004-02	Support, Belt Cover	x	x
35	04017-36	Cpscrw, 1/2-13 x 1" Ser. Fig. HH	x	x
36	04112-05	Nut, 1/2-13 Spiralock	x	x
37	43277	Spacer, J-Hook	x	x
38	04041-12	Flatwasher, 3/8 x 1-1/2 x 16 GA	x	x
39	04021-09	Elastic Stop Nut, 3/8-16	x	x
40	43681	Idler Pivot	x	x
41	461841	Idler Arm Assy. (Inc. 42)	x	x
42	48224	Bearing	x	x
43	04001-62	Cpscrw, 3/8-16 x 3-1/4" Hex Head	x	x
44	44078	J-Hook	x	x

Ref. No.	Part No.	Description	32	36
45	483215	Idler Pulley, Belt Clutch	x	x
46	481024	Seal, Cutter Spindle	x	x
47	43297	Spindle Bushing	x	x
48	43296	Spacer, Inside	x	x
49	481035	Nut, 1.06-18	x	x
50	48677	Relief Fitting, Cutter Spindle	x	x
51	481025	Seal, Cutter Spindle	x	x
52	48098	Spindle Shield	x	x
53	04029-04	Wing Nut, 3/8-16 (Small) RH side	x	x
54	48114-04	Grease Fitting	x	x
55	04021-09	Nut, Hex Elastic Stop 3/8-16	x	x
56	04030-03	Lock Washer, 5/16"	x	x
57	04003-23	Bolt, Carriage 3/8-16 x 1"	x	x
58	423783	Baffle Weldment		x
59	483174	Pad, Deck Wear	x	x
60	04003-12	Bolt, Carriage 5/16-18 x 3/4"	x	x
61	04040-04	Flatwasher, 5/16"	x	x
62	04021-04	Hex Nut, 5/16-18 Center Locknut	x	x
63	424367	Dust Shield	x	x
64	424661	Heatshield	x	x

48V & 52V CUTTER DECKS

Ref. No.	Part No.	Description	48	52	Ref. No.	Part No.	Description	48	52
1	461852	Cutter Deck w/Decals	x		45	461091	Idler Arm Assy. (Incl. 62)	x	x
	461855	Cutter Deck w/Decals		x	46	483176	Pad, Deck Wear	x	x
2	461663	Spindle Assembly	x	x	47	43028	J-Rod, Idler Pulley	x	x
3	43296	Spacer, Inside	x	x	48	43077	Spacer, J-Rod	x	x
4	482744	Pulley	x	x	49	04041-12	Washer, 3/8 x 1-1/2 x 16 ga.	x	x
5	481022	Tapered Bearing	x	x	50	04001-31	Bolt, 3/8-16 x 2-1/2" Hex Head	x	x
6	43644	Spindle Housing	x	x	51	481024	Seal, Cutter Spindle	x	x
7	48114-04	Grease Fitting Str. 5/16"	x	x	52	461841	Idler Arm Assy (Includes 62)	x	x
8	43589	Spindle Shaft	x	x	53	43277	Spacer, J-Rod	x	x
9	43682	Idler Pivot	x	x	54	48677	Reief Fitting, Cutter Spindle	x	x
10	04063-08	Key, 1/4 x 1/4 x 2"	x	x	55	43312	Spacer, Outside, Cutter Spindle	x	x
11	43592	Spacer, Cutter Blade - Small	x	x	56	43297	Spindle Bushing	x	x
12	04001-175	Bolt, 5/16-18 x 1-1/2" Hex Head Gr. 8	x	x	57	481035	Nut, Cutter Spindle	x	x
13	04001-154	Bolt, 5/16-18 x 4-3/4" Hex Head	x	x	58	481625-01	Knob, w/stud	x	x
14	04019-03	Serr. Flange Nut, 5/16-18	x	x	59	04001-51	Bolt, 3/8-16 x 3-3/4" Hex Head	x	x
15	481706	Cutter Blade 16-1/2"	x		60	43681	Idler Pivot	x	x
	481707	Cutter Blade 18"		x	61	483215	Idler Pulley, Belt Clutch	x	x
15A	481710	Cutter Blade 16-1/2 Hi-Lift	x		62	48224	Bearing	x	x
	481711	Cutter Blade 18 Hi-Lift		x	63	04003-12	Bolt, Carriage 5/16-18 x 3/4"	x	x
16	04043-06	Flatwasher, 5/8" (.688 x 1.75 x .134)	x	x	64	482295	Guide Roller	x	x
17	04001-41	Hex Head Bolt, 5/8-11 x 9-1/2"	x	x	65	45944	Roller Shaft	x	x
18	461023	Caster Assembly	x	x	66	481025	Seal, Cutter Spindle	x	x
19	48098	Spindle Shield	x	x	67	483378	Spring, Chute Return	x	x
20	04017-16	Capscrew, 5/16-18 x 3/4"	x	x	68	424839	Baffle Weldment 48V	x	
21	461844	Discharge Chute 48V	x			424840	Baffle Weldment 52V		x
	461845	Discharge Chute 52V		x	69	04001-62	Bolt, 3/8-16 x 3-1/4" Hex Head	x	x
22	04021-10	Nut, 5/16-18 Elastic Elastic Stop	x	x	70	04003-23	Bolt, Carriage 3/8-16 x 1"	x	x
23	04001-11	Bolt, 5/16-18 x 1-1/2" Hex Head	x	x	71	424661	Heatshield	x	x
24	461866	Belt Cover (Incl. decals)	x		72	04021-22	Nut, Hex Lock 5/16-18	x	x
	461867	Belt Cover (Incl. decals)		x	73	04030-03	Lock Washer 5/16"	x	x
25	04043-04	Flat Washer, 3/8" Special	x	x	74	424367	Dust Shield	x	x
26	04029-03	Wing Nut, 3/8-16 (Large)	x	x	75	04001-22	Bolt, 3/8-16 x 2-3/4" Hex Head	x	x
27	04110-03	U-Nut, 3/8-16	x	x					
28	48926	Tapered Hub	x	x					
29	04001-172	Bolt, 1/4-20 x 1" Hex Head Grade 8	x	x					
30	04020-09	Nut, 5/8-11 Hex	x	x					
31	482748	Pulley, Double	x	x					
32	48087	Belt, RH Blade Drive	x						
	48285	Belt, RH Blade Drive		x					
33	48089	Belt, Blade Drive	x						
	483518	Belt, Blade Drive		x					
34	04021-05	Nut, 3/8-16, Nut Centerlock	x	x					
35	04019-04	Nut, 3/8-16, Serrated Flange	x	x					
36	04021-09	Nut, 3/8-16 Elastic Stop	x	x					
37	04004-02	Bolt, 5/16-18 x 1" Hex Head	x	x					
38	04001-09	Bolt, 5/16-18 x 1" Hex Head	x	x					
39	04017-36	Cpscrw, 1/2-13 x 1" Ser. Fig. HH	x	x					
40	04112-05	Nut, 1/2-13 Spiralock	x	x					
41	04021-04	Hex Nut, 5/16-18 Center Locknut	x	x					
42	44078	J-Hook, 48V	x						
	43028	J-Hook, 52V		x					
43	48181	Idler Pulley, "V" Groove	x	x					
44	04040-04	Flatwasher, 5/16"	x	x					

NOTES

CASTER ASSEMBLY

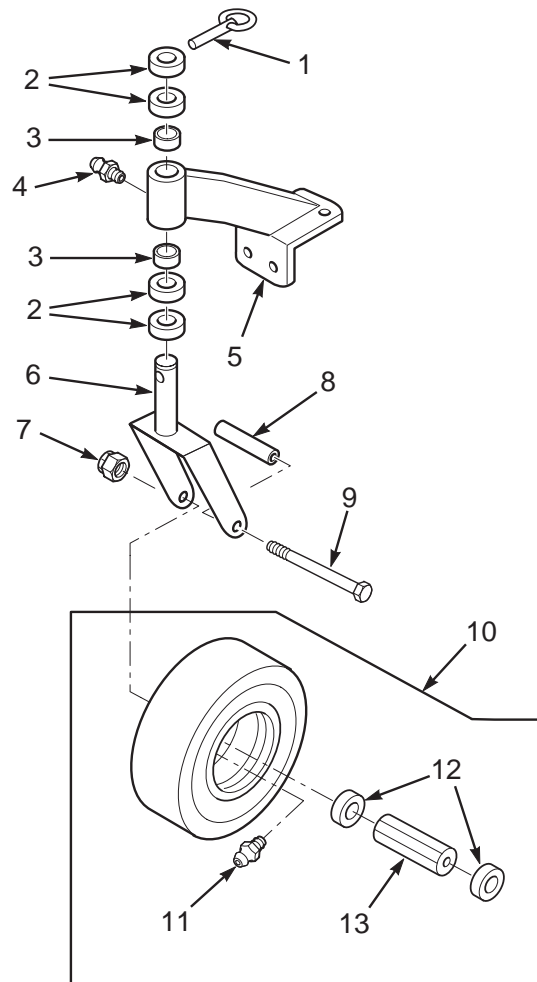

SW-SWZ2006CSTR

Ref. No.	Part No.	Description
1	04066-01	Quick Pin
2	43037-01	Spacer, Spacer Yoke, 1/2" Long
3	48100-01	Bronze Bearing
4	48114-04	Greasing Fitting
5	46082	Support Assembly (Incl. #3 & #4)
6	45006	Caster Yoke
7	04021-07	Nut, Elastic Stop 1/2-13
8	43022	Sleeve, Caster Wheel Bearing
9	04001-37	Bolt, Hex Head 1/2-13 x 5-1/2"
10	9275	Flat-Free Tire Assy. (Incl. #11, #12, #13)
11	48114-03	Grease Fitting, 45 Degree 1/4-28
12	481770	Retainer, Caster Wheel Bearing
13	481769	Roller Bearing, Caster Wheel

ENGINE DECK

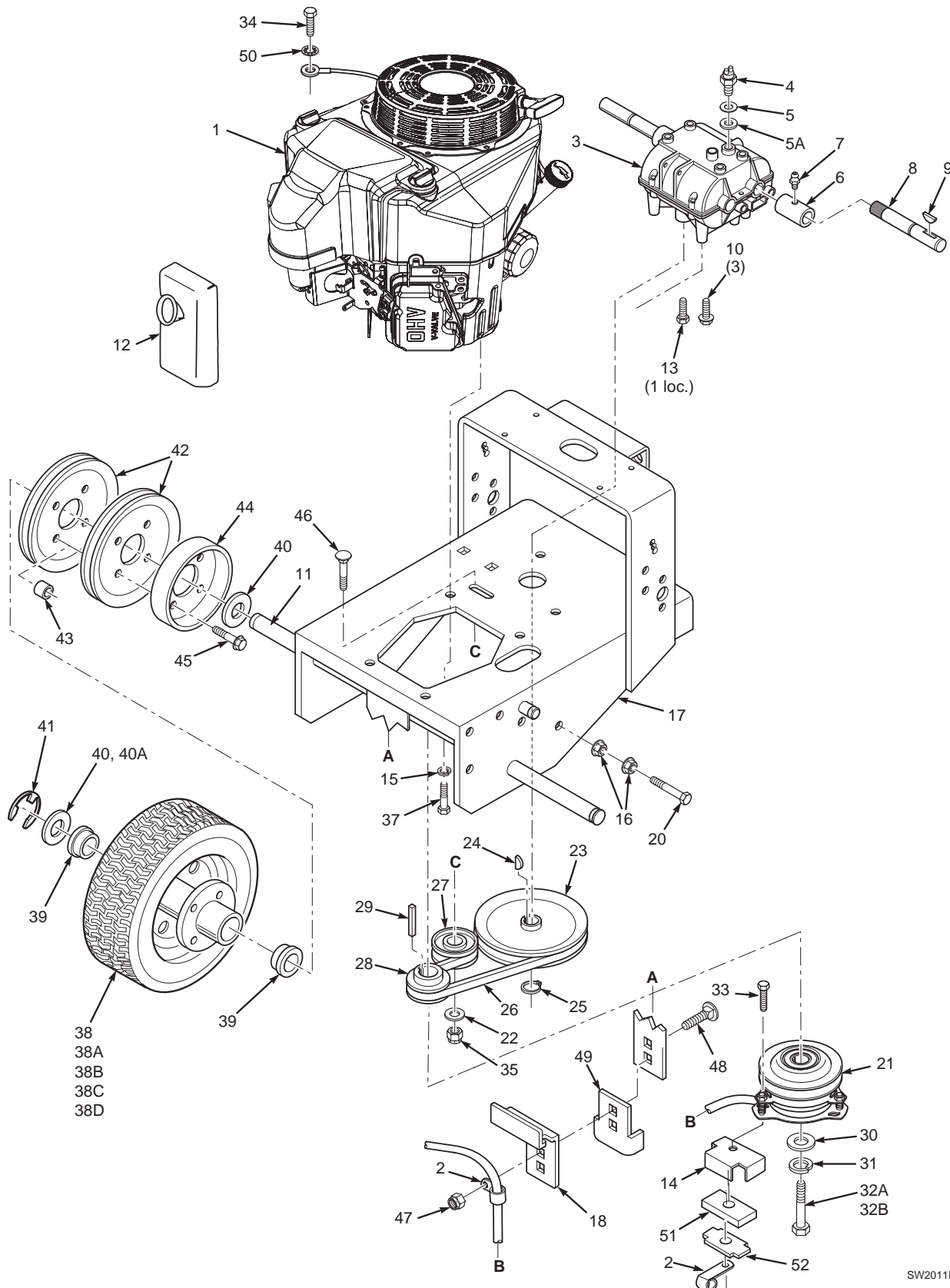

SW2011ED

ENGINE DECK

Ref. No.	Part No.	Description	Ref. No.	Part No.	Description
1	484212	Engine, 16HP Kawasaki (Spec FS481V-XXXX)	29	04063-19	Key, 1/4 x 1/4 x 3/4"
	484213	Engine, 18HP Kawasaki (Spec FS541V-XXXX)	30	04041-28	Flat Washer, 7/16" Special
2	48030-09	Cable Clamp	31	04030-05	Lock Washer, 7/16"
3	481580	Transmission, 5-speed (Peerless 700-070, 9 tooth spline)	32A	04102-04	Bolt, 7/16-20 x 2-1/2" Hex Head
4	48231	Neutral Safety Switch	32B	04103-03	Cpsrw, M10-1.5 x55 Metric Hex Hd
5	48122-01	Fibre Washer, thin	33	04001-12	Bolt, 5/16-18 x 1-3/4" Hex Head
5A	48122-02	Fibre Washer, thick	34	04002-06	Bolt, M8-1.25 x 16
6	481581	Coupler, Jackshaft	35	04021-09	Nut, 3/8-16 Elastic Stop
7	48114-05	Grease Fitting, straight 1/4-28	36	04040-15	Flat Washer, 5/16"
8	481582	Jackshaft (fits SW32,36,48& 52)	37	040001-32	Bolt, Hex Head 3/8-16 x 1-1/4"
9	04063-09	Key, Hi-Pro #9	38	48192	Wheel Assembly (incl. 38A-38B) (fits SW36,48,52)
10	04017-16	Bolt, 5/16-18 X 3/4" Hex Head		48253	Wheel Assembly (Incl. 38C - 38D) (SW32)
11	43085**	Wheel Axle (SW36,48 & 52)	38A	481860	Tire, 13 x 6.50-6, 2-ply (fits SW36,48,52)
	43104**	Wheel Axle (SW 32)	38B	481859	Rim & Bearing Assembly (incl. 39)
12		Muffler (Contact Engine Mfg.)	38C	481861	Tire, 13 x 5.00-6 2-ply (SW32 only)
13	04001-08	Bolt, 5/16-18 X 3/4" Hex Head	38D	481862	Rim Assembly (incl. 39) (SW32 only)
14	422533	Backing Plate	39	481858	Wheel Bearing
15	04030-04	Lock Wshr. 3/8"	40	04042-05	Washer, 1-1/16 x 1-3/4 x 12 ga
16	04019-04	Nut, 3/8-16 Serrated Flange	40A	04041-14	Washer, 1-1/16 x 1-1/2 x 18 ga
17	462285	Engine Deck (fits SW32)	41	04050-08	Retaining Ring, 1" Ext.- "E"
	462286	Engine Deck (fits SW36,48 & 52)	42	48200	Pulley, Wheel Drive
18	424620	Plate, Clutch Bracket	43	43088	Spacer, Wheel Pulley
19	04019-03	Nut, 5/16-18 Serrated Flange	44	48209	Brake Drum
20	04001-51	Bolt, 3/8-16 x 3-3/4" Hex Head	45	04017-19	Bolt, 5/16-18 x 1-1/2" Serrated Flange
21	461397	Electric Clutch (Ogura)	46	04003-03	Bolt, 3/8-16 x 2" Carriage
22	04041-07	Washer, 3/8" (.391 x .938 x .105)	47	04021-10	Nut, 5/16-18 Elastic Stop
23	48197	Pulley, Transmission Input	48	04003-04	Bolt, 5/16-18 x 1" Carriage
24	04063-07	Key, Woodruff #9	49	421370	Anti Rotation Bracket
25	04050-09	Retaining Ring, 5/8" Ext, Basic	50	04031-03	Lock Washer External Tooth
26	48203	Belt, Transmission Drive	51	481716	Rubber Pad, Clutch Stop
27	483208	Idler Pulley, Transmission	52	422534	Plate, Backing
28	481666	Pulley, Traction Drive			

** = Requires welding onto chassis.

HANDLE ASSEMBLY

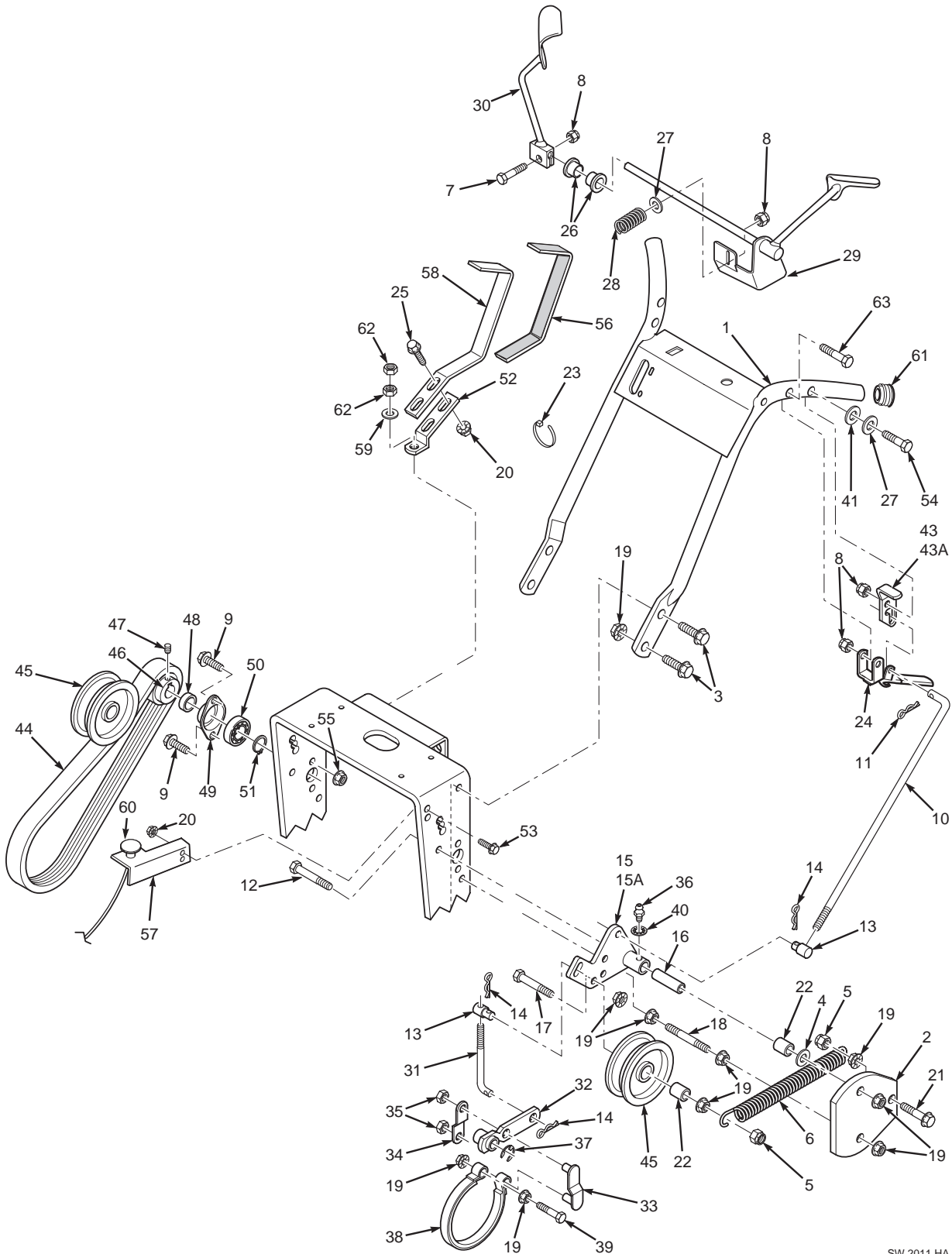

SW 2011 HA

HANDLE ASSEMBLY

Ref. No.	Part No.	Description	Ref. No.	Part No.	Description
1	461972	Handle Assembly	46	482645	Pulley, Jackshaft (Inc. 47)
2	421360	Belt Guard	47	04012-04	Setscrew, Hex Socket Knurl Cup Pt. 5/16-18
3	04017-27	Capscrew, 3/8-16 x 1" Serr. Flg.	48	43098	Spacer, Jackshaft Pulley
4	04041-07	Washer, 3/8" (.391 x .938 x .105)	49	48223	Flange, Jackshaft Bearing
5	04021-09	Nut, 3/8-16 Elastic Stop	50	48224	Bearing, Jackshaft
6	48755	Spring, Idler	51	04050-09	Retaining Ring, 5/8 Ext. Basic
7	04001-10	Bolt, 5/16-18 x 1-1/4" Hex Head	52	422279	Shift Lever
8	04021-10	Nut, 5/16-18 Elastic Stop	53	04017-16	Capscrew, 5/16-18 x 3/4" Serr. Flg.
9	04017-05	Capscrew, 1/4-20 x 3/4" Hex Head	54	04001-17	Bolt, 5/16-18 x 2" Hex Head
10	44140	Control Rod, Steering	55	04019-02	Nut, 1/4-20 Serrated Flange
11	04062-02	Hair Pin, Small	56	481839	Grip, Shift Handle
12	04001-23	Bolt, 3/8-16 x 4-1/2" Hex Head	57	424113	Bracket, Choke Mounting
13	43032	Swivel Joint	58	461163	Shift Lever Extention (incl. 56)
14	04062-01	Hair Pin, Large .094 Dia.	59	04041-07	Washer, 3/8 (.391x .938 x .105)
15	45847	Idler Bracket, RH	60	482314	Choke Control
15A	45846	Idler Bracket, LH	61	483161	Plug, Handlebar
16	43092	Idler Sleeve	62	04020-14	Nut, 3/8-24 UNF
17	04001-62	Bolt, 3/8-16 x 3/4" Hex Head	63	04001-53	Bolt, 5/16-18 x 2-1/2"
18	04004-17	Stud, 3/8-16 x 5"	64	482547	Fuel Tank Cap
19	04019-04	Nut, 3/8-16 Serrated Flange			
20	04019-03	Nut, 5/16-18 Serrated Flange			
21	04017-28	Cpscrew, 3/16-18 x 1-1/4" Serr. Flg			
22	43286	Spacer			
23	48028-05	Cable Tie			
24	483160	Steering Lever			
25	04017-17	Capscrew, 5/16-18 x 1" Serr. Flg.			
26	483142	Bushing			
27	04040-15	Washer, 5/16 (.375 x .875 x .083)			
28	483040	Spring, Operator Presence			
29	451915	Operator Presence Lever, LH			
30	451917	Operator Presence Lever, RH			
31	44005	Brake Rod			
32	45092	Brake Lever			
33	45093	Brake Link			
34	42254	Brake Link Plate			
35	04024-01	Nut, 3/8 Push-on			
36	48114-05	Grease Fitting, Straight 1/4-28			
37	04050-01	Retaining Ring, 5/8 Ext. "E"			
38	48210	Brake Band			
39	04001-45	Bolt, 3/8-16 x 2" Hex Head			
40	04031-08	1/4" Internal Tooth Lockwasher			
41	04032-01	Socket Head Capscrew #8-32 x 1/2"			
42	04015-13	Socket Head Capscrew #8-32 x 1/2"			
43	461242	Neutral Latch, RH			
43A	461241	Neutral Latch, LH			
44	48202A	Belt, Wheel Drive			
45	483211	Idler Pulley, Wheel Drive			

**SW FUEL SYSTEM - EPA PHASE 2
(models produced prior to 1/1/2011)**

Ref. No.	Part No.	Description
1	462289	Fuel Tank Assembly (incl. #3, 4, 5, 6)
2	483792	Fuel Cap
3	484259	Fuel Gauge Assembly (incl. #4)
4	484242	Seal, Fuel Gauge
5	482571	Bushing, .56 Dia. Viton
6	483747	Ball Valve w/Screen
7	48059-01	Clamp, Fuel Hose
8	483617	Fuel Hose, 1/4" ID (order by inch)
9	*	Fuel Filter
10	*	Clamp, Fuel Hose
11	*	Fuel Hose
12	04040-15	Flatwasher, 5/16-.375 x .875 x .083
13	04030-03	Lockwasher, 5/16" Spring
14	04001-09	Bolt, Hex Head 5/16-18 x 1"

* = Available through engine manufacturer only.

**SW FUEL SYSTEM - EPA PHASE 3
(models produced after to 1/1/2011)**

Ref. No.	Part No.	Description
1	462290	Fuel Tank Assembly (incl. #3, 4, 5, 6, 16, 17)
2	484286	Fuel Cap w/ Tether (E.P.A.)
3	484259	Fuel Gauge Assembly (incl. #4)
4	484242	Seal, Fuel Gauge
5	482571	Bushing, .56 Dia. Viton
6	483747	Ball Valve w/Screen
7	48059-01	Clamp, Fuel Hose
8	483617	Fuel Hose, 1/4" ID (order by inch)
9	*	Fuel Filter
10	*	Clamp, Fuel Hose
11	*	Fuel Hose
12	484347	Hose, Vapor Recovery 1/4" (order by inch)
13	04030-03	Lockwasher, 5/16" Spring
14	04001-09	Bolt, Hex Head 5/16-18 x 1"
15	484287	Carbon Canister
16	484285	Grommet, Viton,
17	484333	Fitting, Remote Vent
18	484343-01	Mender, 1/4 x 3/16 w/.02 Hole
19	48030-22	Clamp, 3/8"
20	484345	Hose, Vapor Recovery 3/16" (order by inch)
21	04001-08	Bolt, Hex Head 5/16-18 x 3/4"
22	48059-05	Clamp, Vapor Recovery Hose 3/16"
23	48059-02	Clamp, Fuel Hose 7/32" ID
24	04019-03	Nut, Serrated Flange 5/16-18
25	452176	Bracket, Canister Mounting
26	48136-17	Clamp
27	04003-04	Bolt, Carriage 5/16-18 X 1"
28	484279-01	Tube, Fuel Tank Insert - 4"

* = Available through engine manufacturer only.

**SW FUEL SYSTEM - C.A.R.B. TEIR 3
(LE models only - Produced after 1/1/2010)**

Ref. No.	Part No.	Description
1	462290	Fuel Tank Assembly (incl. #3, 4, 5, 6, 16, 17)
2	484297	Fuel Cap w/ Teether (C.A.R.B.)
3	484259	Fuel Gauge Assembly (incl. #4)
4	484242	Seal, Fuel Gauge
5	482571	Bushing, .56 Dia. Viton
6	483747	Ball Valve w/Screen
7	48059-01	Clamp, Fuel Hose
8	483617	Fuel Hose, 1/4" ID (order by inch)
9	*	Fuel Filter
10	*	Clamp, Fuel Hose
11	*	Fuel Hose
12	484347	Hose, Vapor Recovery 1/4" (order by inch)
13	04030-03	Lockwasher, 5/16" Spring
14	04001-09	Bolt, Hex Head 5/16-18 x 1"
15	484287	Carbon Canister
16	484285	Grommet, Viton,
17	484333	Fitting, Remote Vent
18	484343-01	Mender, 1/4 x 3/16 w/.02 Hole
19	48030-22	Clamp, 3/8"
20	484345	Hose, Vapor Recovery 3/16" (order by inch)
21	04001-08	Bolt, Hex Head 5/16-18 x 3/4"
22	48059-05	Clamp, Vapor Recovery Hose 3/16"
23	48059-02	Clamp, Fuel Hose 7/32" ID
24	04019-03	Nut, Serrated Flange 5/16-18
25	452176	Bracket, Canister Mounting
26	48136-17	Clamp
27	04003-04	Bolt, Carriage 5/16-18 X 1"
28	484279-01	Tube, Fuel Tank Insert - 4"

* = Available through engine manufacturer only.

INSTRUMENT PANEL

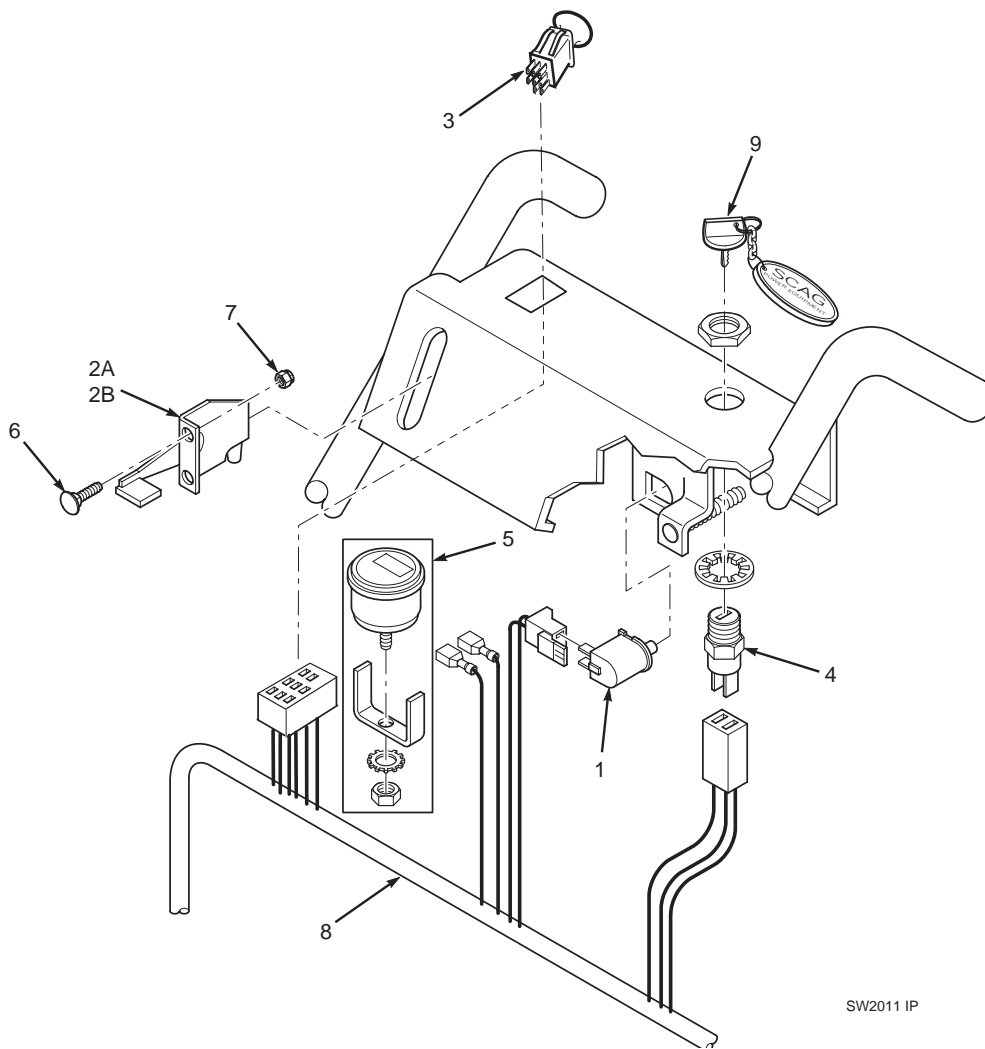

SW2011 IP

Ref. No.	Part No.	Description
1	48717	Switch, Neutral Lock
2A	482814	Throttle Contro - Kohler
2B	48946	Throttle Control - Kawasaki
3	483957	Engagement Switch, Electric Clutch
4	48609	Key Switch
5	48023	Hour Meter (dealer installed)
6	04003-43	Bolt, Carriage #10-32 x 1/2"
7	04021-26	Nut, #10-32 Elastic Stop
8	482711	Handle Wire Harness, Manual Start
9	462069	Key Chain w/Keys
	483609	Key w/Shroud
NS	48030-09	Clamp, Wire Harness

PEERLESS TRANSMISSION 700-070

FOR REFERENCE ONLY - ORDER PARTS FROM PEERLESS / TECUMSEH

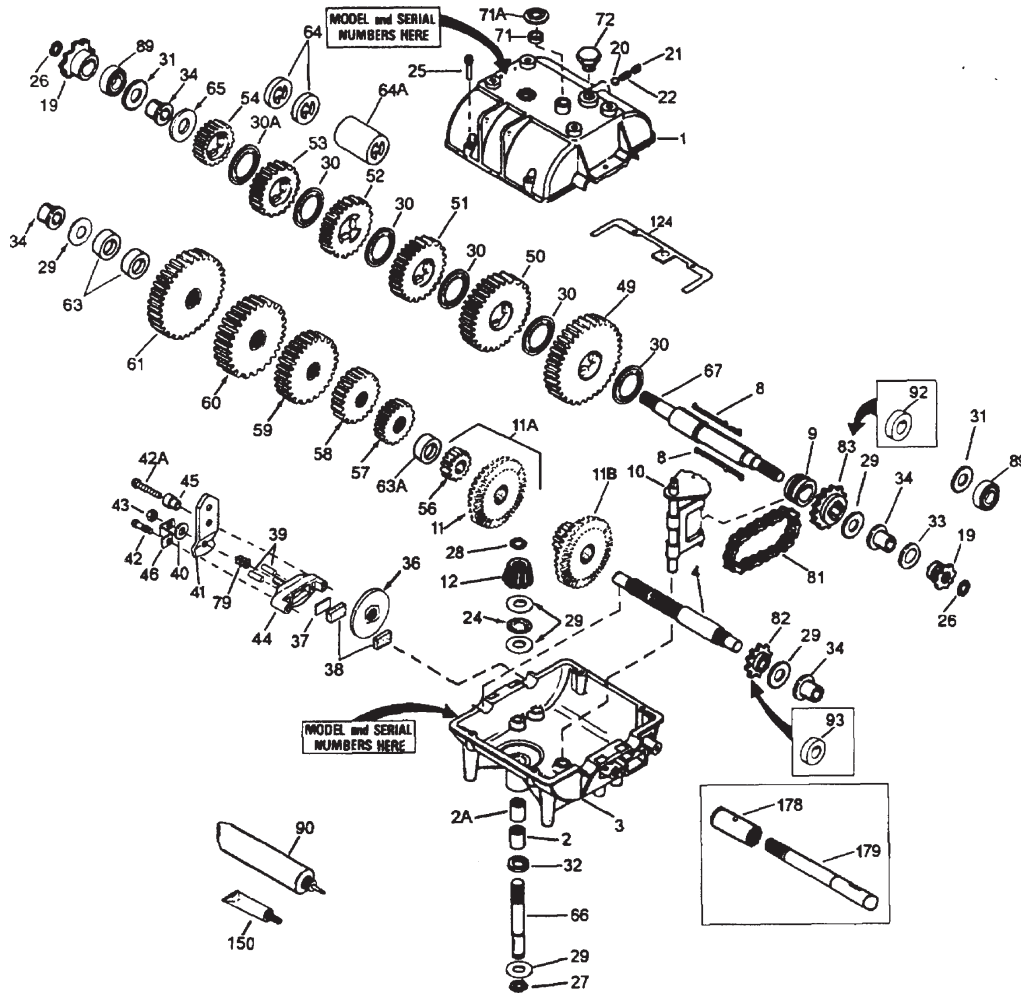

Ref. No.	Part No.	Description	REF. NO.	PART DESCRIPTION
1	772083A	Case, Transmisson	50	778125 Spur Rear (35 teeth)
2	780086A	Needle Bearing Grease Spec	51	778239A Spur Gear (32 teeth-steel)
2A	780142	Needle Bearing	52	778124A Spur Gear (30 teeth)
3	770061A	Case, Transmission	53	778123A Spur Gear (25 teeth)
8	792089A	Shift Key	56	778145 Spur Gear (12 teeth-steel)
9	784266	Shift Collar	57	778151 Spur Gear (15 teeth)
10	784376	Shift Rod & Fork	58	778240 Spur Gear (18 teeth-steel)
11	778154	Bevel Gear (42 teeth)	59	778126A Spur Gear (20 teeth)
12	778176	Bevel Pinion (14 teeth-steel)	60	778127A Spur Gear (25 teeth)
20	792077	Steel Ball, 5/16" dia.	65	780139 Washer
21	792078	Set Screw, 3/8-16 x 3/8"	66	776135 Input Shaft (3-11/16" long)
22	792079	Spring	67	776402 Shifter & Brake Shaft
24	780071	Thrust Bearing	71	788069 Square Cut Ring
25	792073	Screw, 1/4-20 x 1-1/4" (6)	72	792074 Threaded Plug (Shipping only, not used)
27	792035	Retaining Ring	81	786081 Roller Chain (No. 41 chain, 24 links)
28	788040	Retaining Ring	82	786082 Sprocket (9 teeth)
29	780072	Washer (6)	83	786083 Sprocket (18 teeth)
30	780108	Washer (5)	90	788067B Grease (32 oz. bottle Bentonite grease)
32	792001	"O" Ring	150	510334 Gasket Eliminator (Loctite #515)
34	780105A	Flanged Bushing	178	* Coupling (See page 26-27 for part number)
49	778146A	Spur Gear (37 teeth)	179	* Connector Shaft (See page 26-27 for part number)

WIRE HARNESSES

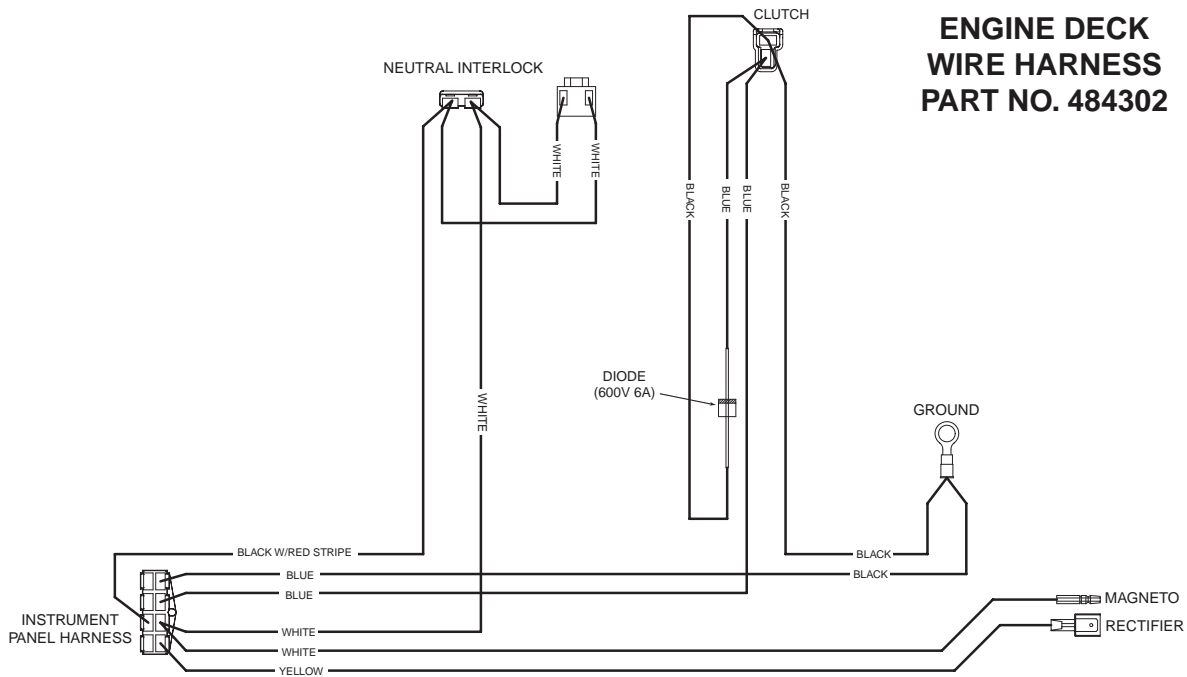

HANDLE WIRE HARNESS PART NO. 482711

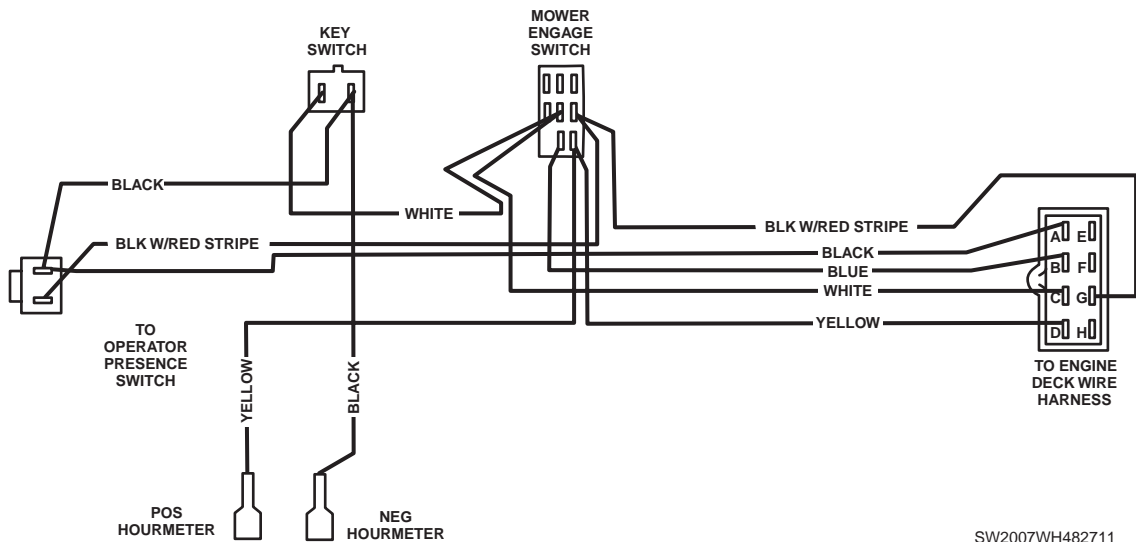

SW2007WH482711

NOTES

REPLACEMENT DECALS AND INFORMATION PLATES



1



2

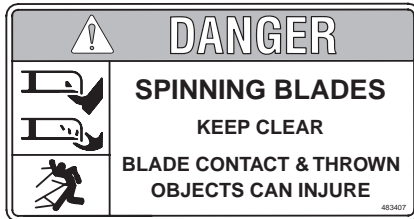

3

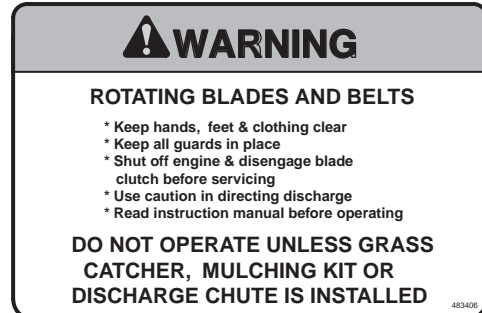

4

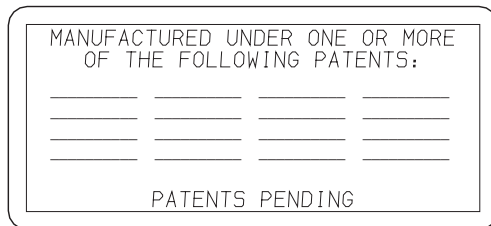

5

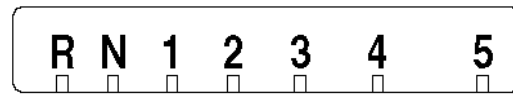

6

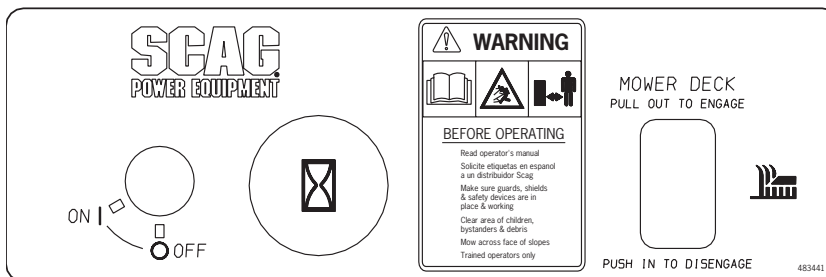

7



8



9



10

REPLACEMENT DECALS AND INFORMATION PLATES

Ref. No.	Part No.	Description
1	483405	Decal, Discharge Chute
2	48314	Decal, Scag Logo
3	483407	Decal, Danger-Spinning Blades
4	483406	Decal, Warning-Rotating Blades
5	483044	Decal, Patents
6	48332	Decal, Shift Index
7	483441	Decal, Instrument Panel - Rear
8	48404	Decal, Metalcraft - Made in USA
9	483404	Decal, Sulky Attachment
10	483402	Decal, Belt Cover
11	481483	Decal, Instrument Panel - Front
12	482816	Decal, Height of Cut
13	48315	Decal, 32
	482297	Decal, 36 Advantage
14	483199	Decal, 48 Velocity Plus
	483200	Decal, 52 Velocity Plus
15	481971	Decal, Heavy Duty Commercial
**	461986	Spanish Decal Kit, Walk-Behinds (Not Shown)
**	483900	Decal, Warning Spark Arrest (Not Shown) - LE Models Only
**	484339	Decal, '10 C.A.R.B. Emissions (Not Shown) - LE Models Only

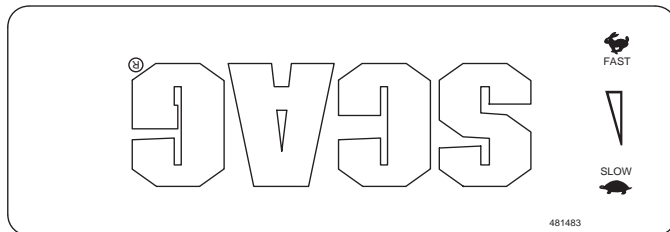

11

482816 **CUTTING HEIGHT ADJUSTMENT**

DECK MOUNTING HOLE POSITION
NUMBER OF CASTER SPACERS (BELOW SUPPORT)

	NUMBER OF SPACERS ABOVE CUTTER BLADES						
	0	1	2	3	4	5	
TOP	0	-	-	2-3/8	2-1/8	1-7/8	1-5/8
MIDDLE	0	-	-	2-5/8	2-3/8	2-1/8	1-7/8
MIDDLE	1	-	-	2-3/4	2-1/2	2-1/4	2
BOTTOM	2	-	-	-	-	2-7/8	2-5/8
BOTTOM	3	-	4	3-3/4	3-1/2	3-1/4	3
BOTTOM	4	4-3/8	4-1/8	3-7/8	3-5/8	3-3/8	3-1/8

12



13



14



15