

SCAG[®]

POWER EQUIPMENT

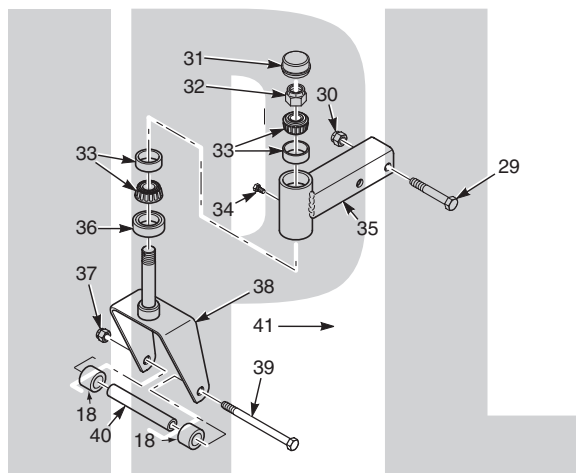

ILLUSTRATED PARTS MANUAL



Model STWC Wildcat

THIS MANUAL CONTAINS THE ILLUSTRATED PARTS LIST FOR MODELS:

STWC48V-25CV
STWC48V-26KA-LC
STWC52V-26FX
STWC52V-26KA-LC
STWC61V-26KA-LC
STWC61V-27CV

with a serial number of F4400001 to F4499999
with a serial number of F4500001 to F4599999
with a serial number of F4600001 to F4699999
with a serial number of F4700001 to F4799999
with a serial number of F4800001 to F4899999
with a serial number of F4900001 to F4999999

Table of Contents

48V & 52V CUTTER DECKS	2
61V CUTTER DECK	4
CUTTER DECK CONTROLS	6
SHEET METAL COMPONENTS	8
STWC ROLL-OVER PROTECTION SYSTEM	10
STWC SUSPENSION SEAT	12
NOTES.....	13
DRIVE SYSTEM COMPONENTS	14
ENGINE AND ATTACHING PARTS	16
STEERING COMPONENTS.....	18
BRAKE COMPONENTS	20
HYDRAULIC SYSTEM	22
STWC FUEL SYSTEM - EPA PHASE 2.....	24
STWC FUEL SYSTEM - EPA PHASE 3.....	26
ELECTRICAL SYSTEM - KOHLER & KAWASAKI AIR-COOLED	28
ELECTRICAL SYSTEM - 26HP KAWASAKI LIQUID-COOLED	30
HYDRAULIC PUMP ASSEMBLY	32
REPLACEMENT DECALS AND INFORMATION PLATES	34
ELECTRICAL SCHEMATIC - KOHLER AIR-COOLED	36
ELECTRICAL SCHEMATIC - KAWASAKI AIR-COOLED	37
ELECTRICAL SCHEMATIC - 26HP KAWASAKI LIQUID-COOLED	38

48V & 52V CUTTER DECKS

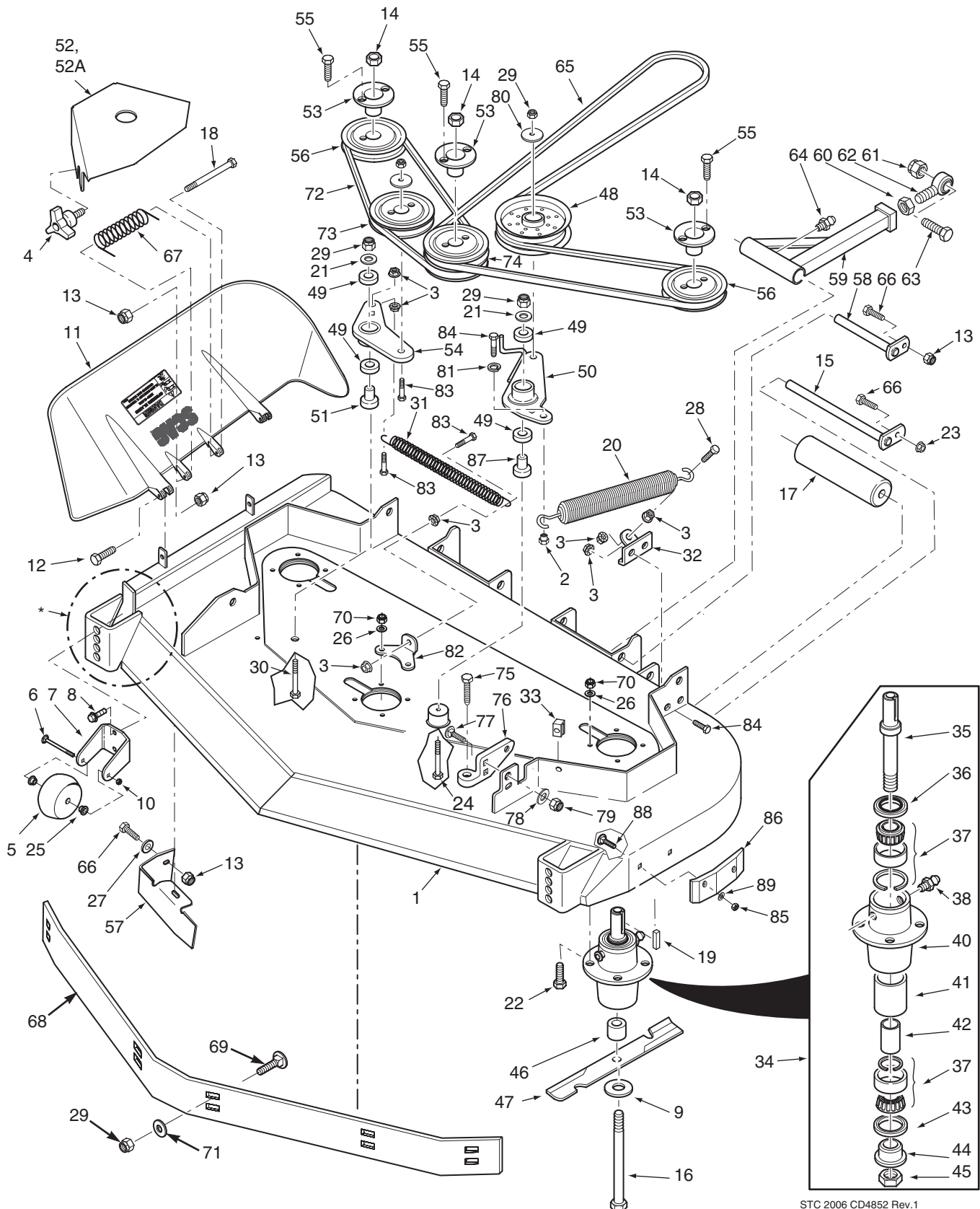

* 52" cutter deck has a notch for anti-scalp roller

STC 2006 CD4852 Rev.1

48V & 52V CUTTER DECKS

Ref. No.	Part No.	Description	48	52
1	461854	Cutter Deck Velocity Plus	X	
	461858	Cutter Deck Velocity Plus		X
2	43686	Boss, Spring Anchor	X	X
3	04019-04	Nut, 3/8-16 Serrated Flange	X	X
4	481625-01	Wing Nut, 3/8-16	X	X
5	481632	Anti-Scalp Wheel	X	X
6	04003-26	Bolt, Carriage 3/8-16 x 4"	X	X
7	422478	Bracket, Anti-Scalp Wheel	X	X
8	04017-27	Bolt, Serrated Flange 3/8-16 x 1"	X	X
9	04043-06	Flatwasher, 5/8" Hardened	X	X
10	04021-05	Locknut, 3/8-16 Center Lock	X	X
11	461844	Discharge Chute	X	
	461845	Discharge Chute		X
12	04001-11	Bolt, Hex Head 5/16-18 x 1-1/2", Rear	X	X
	04001-12	Bolt, Hex Head 5/16-18 x 1-3/4", Front	X	X
13	04021-10	Nut, Elastic Stop 5/16-18	X	X
14	04020-09	Nut, 5/8-11 UNC	X	X
15	45944	Shaft, Roller	X	X
16	04001-41	Bolt, Hex Head 5/8-11 x 9-1/2"	X	X
17	48038	Roller, Rear	X	X
18	04001-154	Bolt, Hex Head 5/16-18 x 4-3/4"	X	X
19	04063-08	Key, 1/4 x 1/4 x 2"	X	X
20	483246	Spring, Idler LH	X	X
21	04043-04	Flatwasher, 3/8"	X	X
22	04001-176	Bolt, Hex Head 5/16-18 x 1-3/4" Gr. 8	X	X
23	04019-03	Nut, Serrated Flange 5/16-18	X	X
24	04001-51	Bolt, Hex Head 3/8-16 x 3-3/4"	X	X
25	48100-15	Bushing, .376 ID Oilite	X	X
26	04030-03	Lockwasher 5/16"	X	X
27	04040-15	Flatwasher 5/16"	X	X
28	04001-136	Bolt, Hex Head 3/8-16 x 1-1/2" Gr. 8	X	X
29	04021-09	Nut, Elastic Stop 3/8-16	X	X
30	04001-31	Bolt, Hex Head 3/8-16 x 2-1/2"	X	X
31	483247	Spring, Idler RH	X	X
32	424369	Bracket, Spring Anchor LH 48V	X	
	424409	Bracket, Spring Anchor LH 52V		X
33	04110-03	U-Nut, 3/8-16	X	X
34	461663	Spindle Assembly	X	X
35	43589	Shaft, Spindle	X	X
36	481024	Seal Upper	X	X
37	481022	Bearing Assembly	X	X
38	48114-04	Grease Fitting	X	X
39	48677	Valve, Grease Relief	X	X
40	43644	Housing, Spindle	X	X
41	43312	Spacer, Outside	X	X
42	43296	Spacer, Inside	X	X
43	481025	Seal, Lower	X	X
44	43297	Bushing, Bottom	X	X
45	481035	Nut, Special 1-1/16 - 18	X	X
46	43590	Spacer, Spindle	X	X
47	482877	Cutter Blade 16.5"	X	
	482878	Cutter Blade 18"		X
48	483210	Pulley, Idler 5" Dia.	X	X
49	48224	Bearing	X	X
50	461940	Idler Arm Assy.	X	X

Ref. No.	Part No.	Description	48	52
51	43689	Idler Pivot	X	X
52	424322	Belt Cover (48V)	X	
	424323	Belt Cover (52V)		X
53	48926	Hub, Tapered 1-1/8" Bore	X	X
54	461946	Idler Arm	X	X
55	04001-172	Bolt, Hex Head 1/4-20 x 1" Grade 8	X	X
56	483282	Pulley 4.75"	X	
	483284	Pulley 5.35"		X
57	424208	Turbo Baffle, Bolt On	X	X
58	451240	Push Arm Shaft	X	X
59	461516	Push Arm (Includes 64,60,62)	X	X
60	04020-16	Nut, 5/8-18 UNF	X	X
61	04021-13	Nut, Elastic Stop 5/8-11	X	X
62	48763	Rod End, 5/8 Male RH Thread	X	X
63	04001-79	Bolt, Hex Head 5/8-11 x 4-1/2"	X	X
64	48114-04	Grease Fitting, 90 Degree	X	X
65	483241	Belt, Cutter Deck Drive (48V)	X	
	483242	Belt, Cutter Deck Drive (52V)		X
66	04001-09	Bolt, Hex Head 5/16-18 x 1"	X	X
67	483378	Spring, Discharge Chute	X	X
68	424173	Baffle Custom-Cut, 48V (3-Position)	X	
	424839	Baffle Custom-Cut, 48V (7-Position)	X	
	424174	Baffle Weldment, 52V (3-Position)		X
	424840	Baffle Custom-Cut, 52V (7-Position)		X
69	04003-23	Bolt, Carriage 3/8-16 x 1"	X	X
70	04021-22	Nut, Elastic Stop 5/16-18 Grade 8	X	X
71	04043-04	Flatwasher 3/8"	X	X
72	483239	Belt, RH Cutter Deck	X	
	483240	Belt, RH Cutter Deck		X
73	48181	Pulley, Idler 5" Dia.	X	X
74	483283	Pulley, Double Groove	X	
	483285	Pulley, Double Groove		X
75	483167	Bolt, Special	X	X
76	461929	Lever Assy., Deck Level	X	X
77	04003-40	Bolt, Carriage 7/16-14 x 1-1/4"	X	X
78	04040-11	Flatwasher, 7/16-.500 x 1.25 x .083"	X	X
79	04021-11	Nut, Elastic Stop 7/16-14	X	X
80	424367	Dust Shield	X	X
81	04030-03	Lockwasher 3/8"	X	X
82	424376	Bracket, Spring Anchor RH	X	
	424377	Bracket, Spring Anchor RH		X
83	04001-136	Bolt, Hex Head 3/8-16 x 1-1/2" Gr. 8	X	X
84	04001-19	Bolt, Hex Head 3/8-16 x 1"	X	X
85	04021-04	Nut, Center Lock 5/16-18	X	X
86	483176	Wear Pad	X	X
87	43689	Idler Pivot	X	X
88	04003-12	Bolt, Carriage 5/16-18 x 3/4"	X	X
89	04040-04	Flatwasher, 5/16"	X	X

61V CUTTER DECK

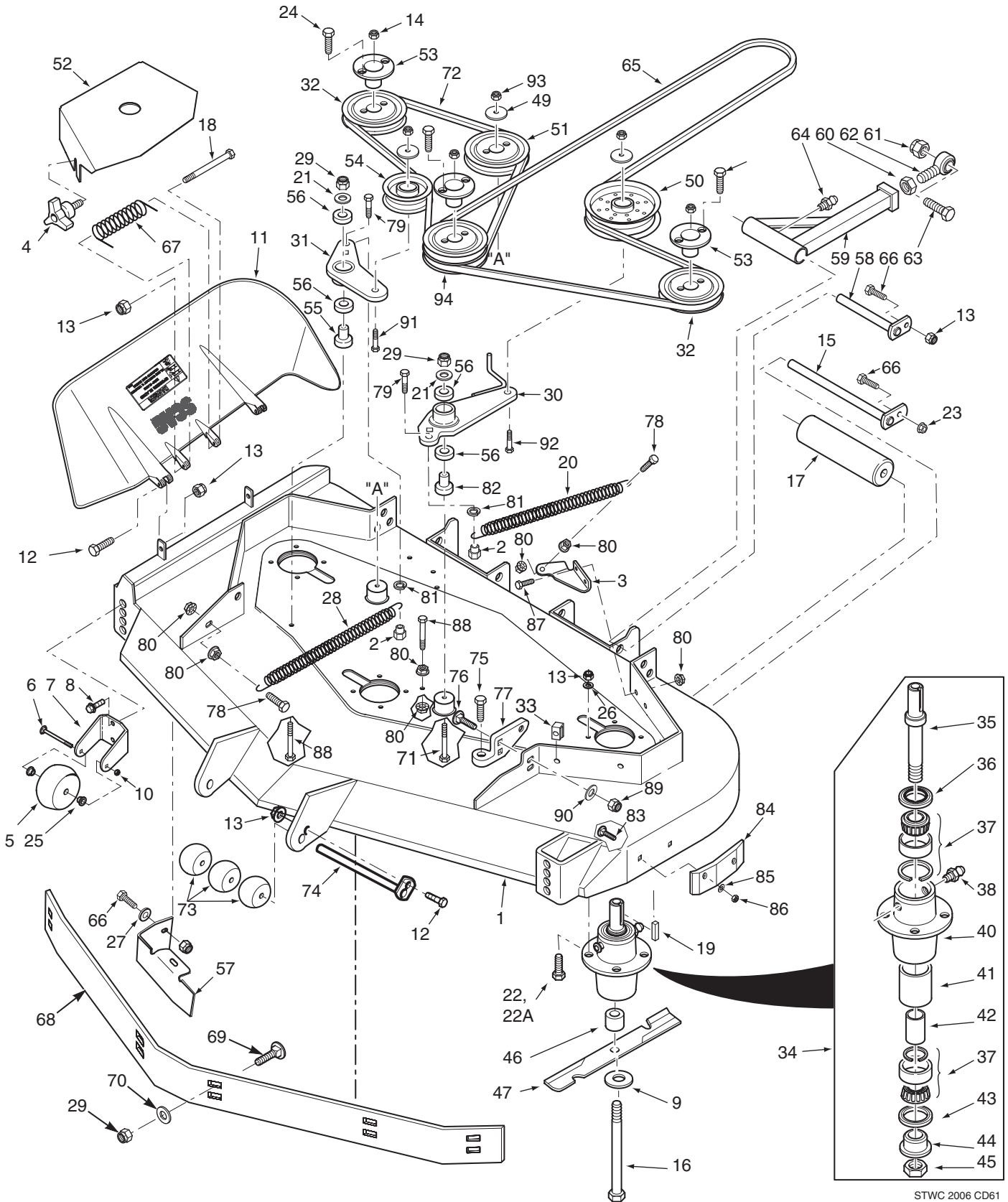

STWC 2006 CD61

61V CUTTER DECK

Ref. No.	Part No.	Description
1	461862	Cutter Deck Velocity Plus
2	43687	Boss, Spring Anchor
3	424371	Bracket, LH Spring Anchor 61V
4	481625-01	Wing Nut, 3/8-16
5	481632	Anti-Scalp Wheel
6	04003-26	Bolt, Carriage 3/8-16 x 4"
7	422478	Bracket, Anti-Scalp Wheel
8	04017-27	Bolt, Serr. Flng. 3/8-16 x 1"
9	04043-06	Flatwasher, 5/8" Hardened
10	04021-05	Locknut, 3/8-16 Center Lock
11	461846	Discharge Chute
12	04001-11	Bolt, Hex Hd. 5/16-18 x 1-1/2", Rear
	04001-12	Bolt, Hex Hd. 5/16-18 x 1-3/4", Front
13	04021-10	Nut, Elastic Stop 5/16-18
14	04020-09	Nut, 5/8-11 UNC
15	45944	Shaft, Roller
16	04001-41	Bolt, Hex Hd. 5/8-11 x 9-1/2"
17	48038	Roller, Rear
18	04001-154	Bolt, Hex Hd. 5/16-18 x 4-3/4"
19	04063-08	Key, 1/4 x 1/4 x 2"
20	483246	Spring, LH Deck Drive
21	04043-04	Flatwasher, 3/8" (.938 x .391 x .105")
22	04001-176	Bolt, Hex Hd. 5/16-18 x 1-3/4" Grd. 8
23	04019-03	Nut, Serr. Flng. 5/16-18
24	04001-172	Bolt, Hex Hd. 1/4-20 x 1" Grd. 8
25	48100-15	Bushing, .376 ID Oilite®
26	04030-03	Lockwasher 5/16"
27	04040-15	Flatwasher 5/16"
28	483703	Spring, RH Deck Drive
29	04021-09	Nut, Elastic Stop 3/8-16
30	461940	Idler Arm Assembly, LH Drive
31	461946	Idler Arm Assembly, RH Drive
32	483286	Pulley, Tapered Bore 6.33" Dia.
33	04110-03	U-Nut, 3/8-16
34	461663	Spindle Assembly
35	43589	Shaft, Spindle
36	481024	Seal Upper
37	481022	Bearing Assembly
38	48114-04	Grease Fitting
39	48677	Valve, Grease Relief
40	43644	Housing, Spindle
41	43312	Spacer, Outside
42	43296	Spacer, Inside
43	481025	Seal, Lower
44	43297	Bushing, Bottom
45	481035	Nut, Special 1-1/16 - 18
46	43590	Spacer, Spindle
47	482879	Cutter Blade 21"
48	483287	Pulley, Double Groove 6.33" Dia.
49	424367	Dust Shield
50	483210	Idler Pulley, 5" Dia.

Ref. No.	Part No.	Description
51	48181	Idler Pulley, 5" Dia.
52	424575	Belt Cover (61V)
53	48926	Hub, Tapered 1-1/8" Bore
54	483415	Idler Pulley, 3-1/2" Dia.
55	43689	Pivot, Idler
56	48224	Bearing
57	424209	Turbo Baffle, Bolt On
58	451240	Push Arm Shaft
59	461516	Push Arm (Incl. 64, 60, 62)
60	04020-16	Nut, 5/8-18 UNF
61	04021-13	Nut, Elastic Stop 5/8-11
62	48763	Rod End, 5/8 Male RH Thread
63	04001-79	Bolt, Hex Hd. 5/8-11 x 4-1/2"
64	48114-04	Grease Fitting, 90 Degree
65	483243	Belt, Deck Drive 61V
66	04001-09	Bolt, Hex Hd. 5/16-18 x 1"
67	483378	Spring, Discharge Chute
68	424841	Baffle Weldment, 61V
69	04003-23	Bolt, Carriage 3/8-16 x 1"
70	04041-07	Flatwasher, 3/8 (.391 x .938 x .105")
71	04001-77	Bolt, Hex Hd. 3/8-16 X 3-1/2"
72	483157	Belt, Deck Drive RH
73	482295	Wheel, Anti Scalp
74	45944	Roller Shaft
75	483167	Bolt, Special
76	04003-40	Bolt, Carriage 7/16-14 x 1-1/4"
77	461929	Lever Assy., Deck Level
78	04001-136	Bolt, Hex Hd. 3/8-16 x 1-1/2" Grd. 8
79	04001-19	Bolt, Hex Hd. 3/8-16 x 1"
80	04019-04	Nut, Serr. Flng. 3/8-16
81	04030-04	Lockwasher, 5/16"
82	43689	Pivot, Idler Short
83	04003-12	Bolt, Carr. 5/16-18 x 3/4"
84	483176	Wear Pad
85	04040-04	Flatwasher, 5/16 (.344 x .688 x .065")
86	04021-04	Nut, Center Lock 5/16"
87	04001-19	Bolt, Hex Hd. 3/8-16 x 1"
88	04001-31	Bolt, Hex Hd. 3/8-16 x 2-1/2"
89	04021-11	Nut, Elastic Stop 7/16-14
90	04040-11	Flatwasher, 7/16 (.500 x 1.250 x .083")
91	04001-46	Bolt, Hex Hd. 3/8-16 x 2-1/4"
92	04001-54	Bolt, Hex Hd. 3/8-16 x 3"
93	04021-09	Nut, Elastic Stop 3/8-16
94	483287	Pulley, Double Groove 6.33" Dia.

CUTTER DECK CONTROLS

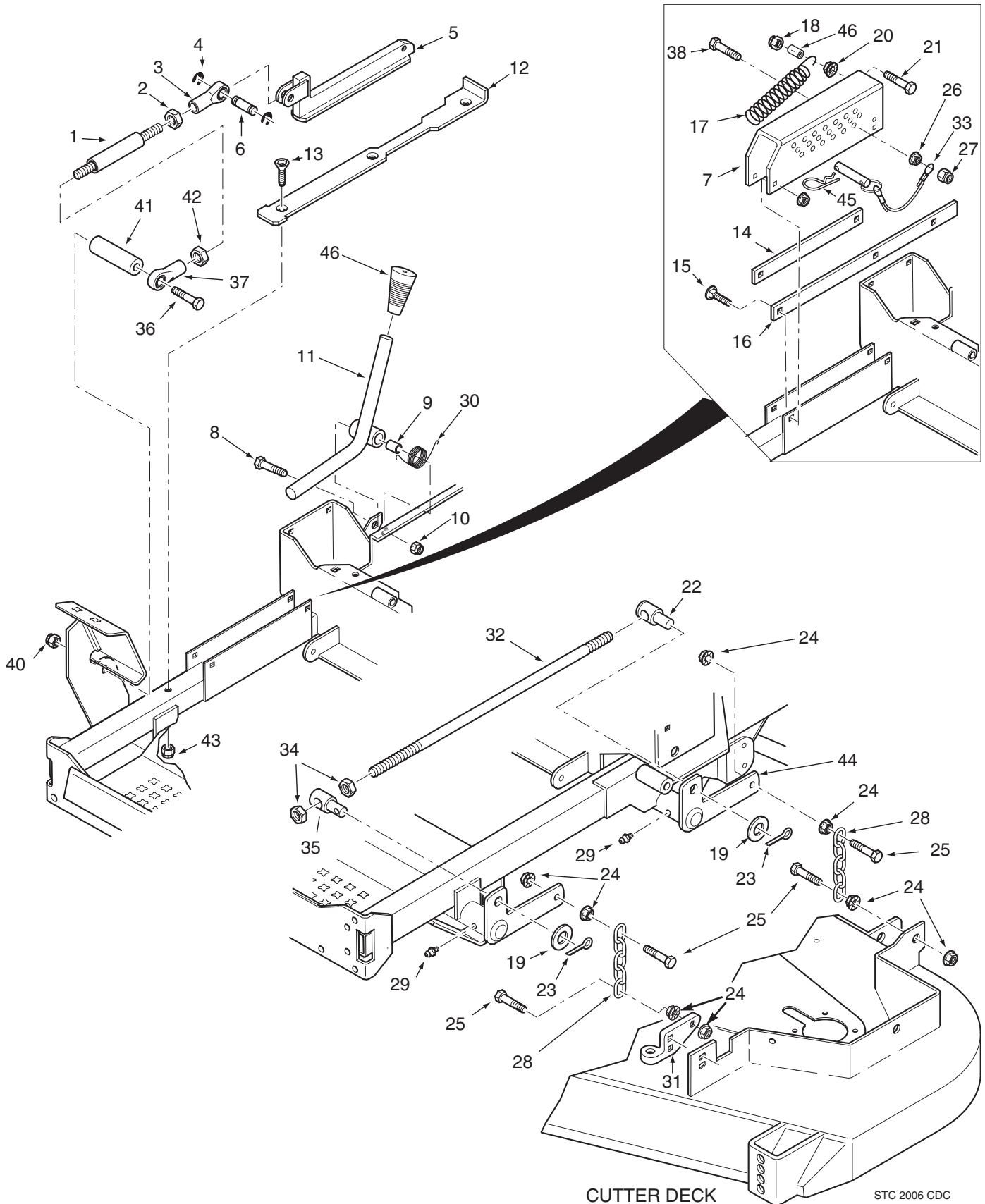

CUTTER DECK CONTROLS

Ref. No.	Part No.	Description
1	482624	Rod, Deck Lift Linkage
2	04020-28	Nut, Jam 1/2-20 LH Thread
3	481766	Rod End, 1/2-20 Female LH Thread
4	04050-10	Retaining Ring, 1/2" Ext. "E"
5	483062	Slide, Deck Height Adjust
6	43487	Pin, Deck Lift
7	423463	Bracket, Cutting Height Adjustment
8	04001-22	Bolt, Hex Hd. 3/8-16 x 2-3/4"
9	43668	Bushing .502" OD
10	04021-09	Nut, Elastic Stop 3/8-16
11	461874	Lever, Deck Latch
12	422346	Slide, Cutting Height
13	04014-03	Capscrew, 5/16-18 x 3" Flathead Hex Socket Grd. 8
14	422381	Guide, Short
15	04003-04	Bolt, Carriage 5/16-18 x 1"
16	422380	Guide, Long
17	483177	Spring, Helper
18	04021-05	Nut, 3/8-16 Center Lock
19	04040-09	Flatwasher, 5/8 (.656 x 1.312 x .095")
20	04019-04	Nut, 3/8-16 Serr. Flng.
21	04001-32	Bolt, Hex Hd. 3/8-16 x 1-1/4"
22	43678	Swivel Joint LH
23	04061-07	Cotter Pin, 3/16 x 1"
24	04019-04	Nut, Serr. Flng. 3/8-16
25	04001-20	Bolt, Hex Hd. 3/8-16 x 1-1/2"
26	04019-04	Nut, Serr. Flng. 3/8-16
27	04021-09	Nut, Elastic Stop 3/8-16
28	48540	Chain
29	48114-04	Grease Fitting, 1/4-28 Self Tap
30	483181	Torsion Spring
31	461929	Lever Assy., Deck Level
32	04004-45	Stud, 1/2-13 x 20"
33	04067-09	Pin
	481547	Lanyard
34	04020-09	Nut, 5/8-11 UNC
35	43679	Swivel Joint RH
36	04001-155	Bolt, Hex Hd. 1/2-13 x 5"
37	481765	Rod End, 1/2-20 Female RH Thread
38	04001-77	Bolt, Hex Hd. 3/8-16 x 3-1/2"
39	43572	Spacer
40	04021-02	Locknut, 1/4-20
41	43630	Spacer
42	04020-27	Nut, 1/2-20 UNF-2B RH Thread
43	04021-10	Nut, Elastic Stop 5/16-18
44	45904	Lift Bellcrank Weldment, LH Rear
	45905	Lift Bellcrank Weldment, RH Rear
	04041-14	Flatwasher, 1.0 (1.062 x 1.5 x .048")
	04050-08	Retaining Ring, 1" Ext.
45	04062-04	Hair Pin Cotter, .177" x 3-1/4"
46	481477	Grip, Deck Latch Lever

SHEET METAL COMPONENTS

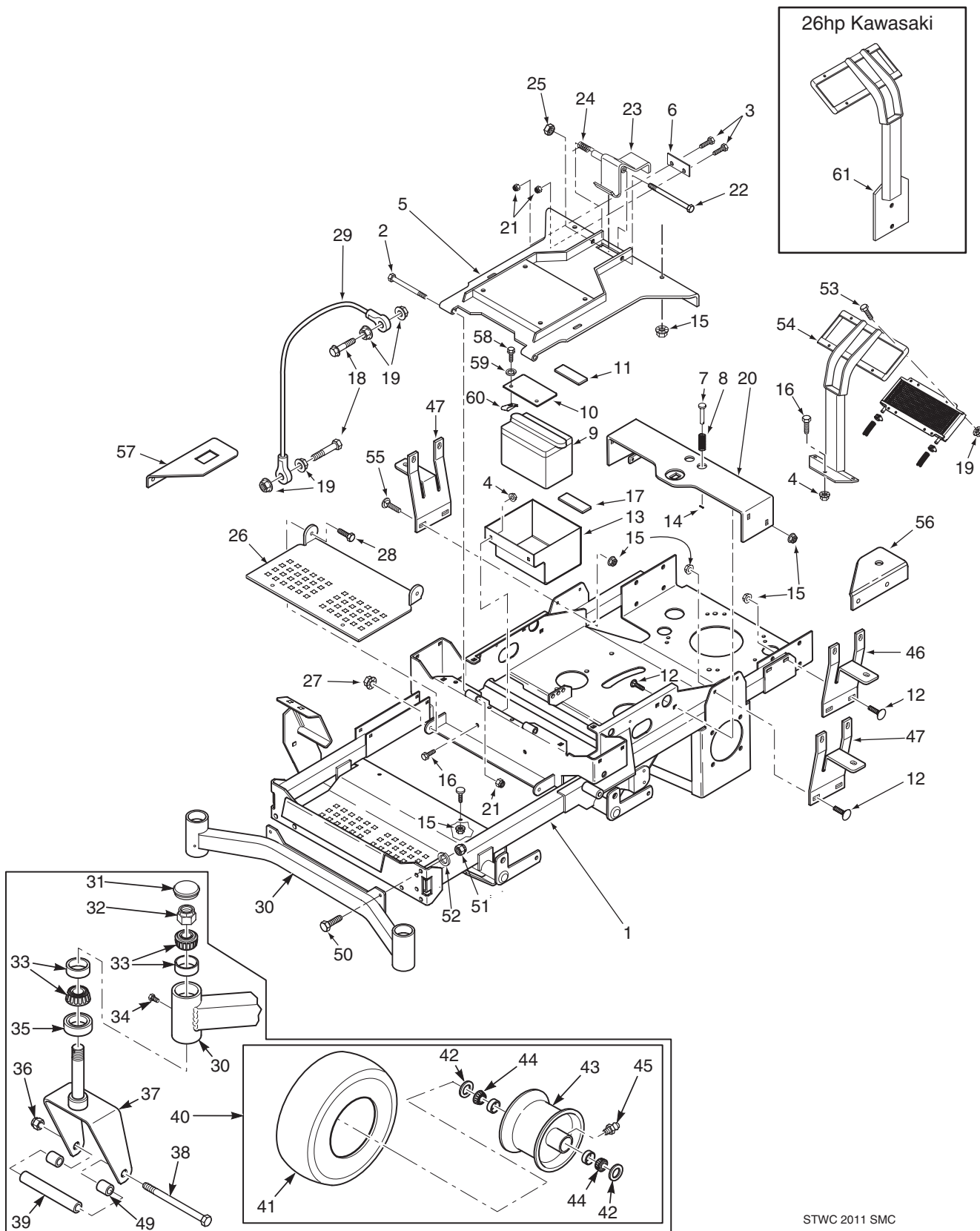

STWC 2011 SMC

SHEET METAL COMPONENTS

Ref. No.	Part No.	Description
1	462325	Main Frame Assembly w/Decals
2	04001-73	Bolt, Hex Hd. 5/16-18 x 3-3/4"
3	04001-09	Bolt, Hex Hd. 5/16-18 x 1"
4	04019-04	Nut, Serr. Flng. 3/8-16
5	461989	Plate, Seat Mounting
6	424584	Seat Stop
7	43462	Pin Retainer, Spring
8	481389	Spring
9	**	Battery (not available through Scag)
10	423571	Battery Cover
11	482553	Battery Hold Down Pad
12	04003-12	Bolt, Carr. 5/16-18 x 3/4"
13	423556	Battery Box
14	04060-01	Roll Pin, Spring 5/32 x 3/4"
15	04019-03	Nut, Serr. Flng. 5/16-18
16	04001-19	Bolt, Hex Hd. 3/8-16 x 1"
17	482552	Pad, Rubber
18	04001-59	Bolt, Hex Hd. 1/4-20 x 1-1/4"
19	04019-02	Nut, Serr. Flng. 1/4-20
20	451896	Seat Base Support
21	04021-10	Nut, Elastic Stop 5/16-18
22	04001-100	Bolt, Hex Hd. 3/8-16 x 6"
23	451897	Seat Latch Weldment
24	483371	Spring, Seat Latch
25	04021-05	Locknut, 3/8-16 Center Lock
26	423557	Footplate
27	04021-09	Nut, Elastic Stop 3/8-16
28	04001-19	Bolt, Hex Hd. 3/8-16 x 1"
29	48566	Cable, Seat Stop
30	452205	Weldment, Caster Support (61V)
	452204	Weldment, Caster Support (48V & 52V)
31	484195	Cap, Grease
32	04021-20	Nut, Elastic Stop 1.0-14
33	48668	Bearing Set
34	482028-01	Plug, 1/4-28
35	481025	Seal, 2.0" OD x 1.625" ID
36	04021-07	Nut, Elastic Stop 1/2-13
37	451658	Yoke, Front Caster Wheel
38	04001-167	Bolt, Hex Hd. 1/2-13 x 9-1/2"
39	43583	Sleeve
40	9278	Caster Wheel Assembly (Incl. 41 thru 45)
41	482619	Tire, 13 x 6.5-6 Smooth
42	482622	Seal
43	482620	Rim (Incl. Item 45)
44	482621	Roller Bearing
45	48114-10	Fitting, Grease

Ref. No.	Part No.	Description
46	423575	Mounting Bracket, Oil Tank
47	423764	Mounting Bracket, Fuel Tank
48	482633	Seat Pan
49	43584	Spacer, Caster Wheel
50	04001-28	Bolt, Hex Hd. 7/16-14 x 1-1/4"
51	04021-11	Nut, Elastic Stop 7/16-14
52	04030-05	Lockwasher, 7/16"
53	04001-06	Bolt, Hex Hd. 1/4-20 x 5/8"
54	451580	Support Weldment, Oil Cooler
55	04003-04	Bolt, Carriage 5/16-18 x 1"
56	423912	Bracket, Fuel Valve
57	424112	Bracket, Hour Meter
58	04001-32	Bolt, Hex Hd. 3/8-16 x 1-1/4"
59	04030-04	Lockwasher, 3/8" Spring
60	04110-03	U-Nut, 3/8-16
61	451840	Support Weld, Oil Cooler - 26hp Kaw.

STWC ROLL-OVER PROTECTION SYSTEM

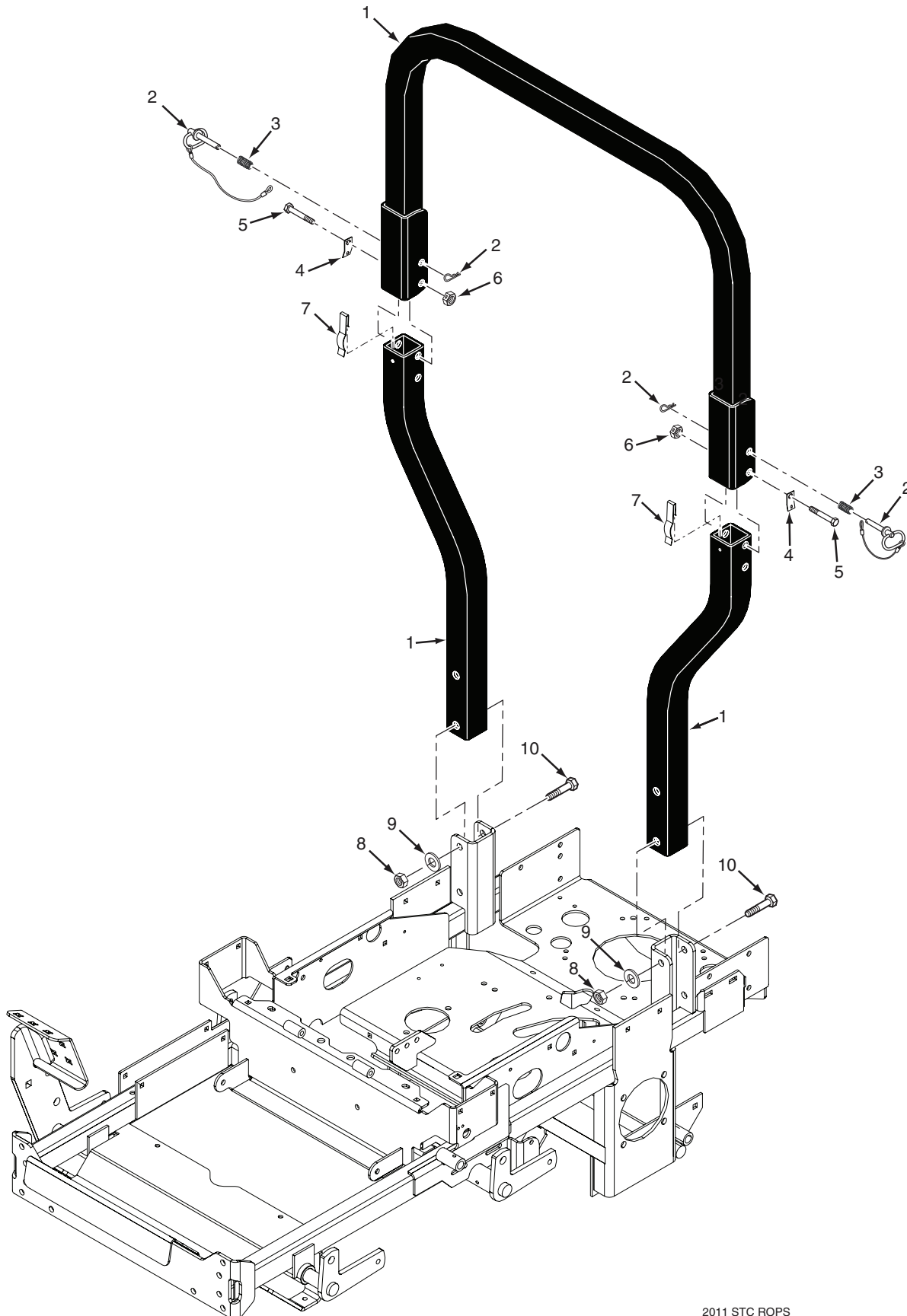

STWC ROLL-OVER PROTECTION SYSTEM

Ref. No.	Part No.	Description
1	462209	STC Foldable ROPS
2	484168	Pin Assembly (incl. #3 & #4)
3	484170	Spring, ROPS
4	484169	Clip, ROPS
5	04001-90	Bolt, Hex Head 1/2-13 x 3-1/4"
6	04021-19	Nut, Center Lock 1/2-13
7	484167	Spring Clip, ROPS
8	04021-19	Nut, Center Lock 1/2-13
9	04040-13	Flatwasher, 1/2-.562 x 1.375 x .109
10	04001-145	Bolt, Hex Head 1/2-13 x 3-1/2"

STWC SUSPENSION SEAT

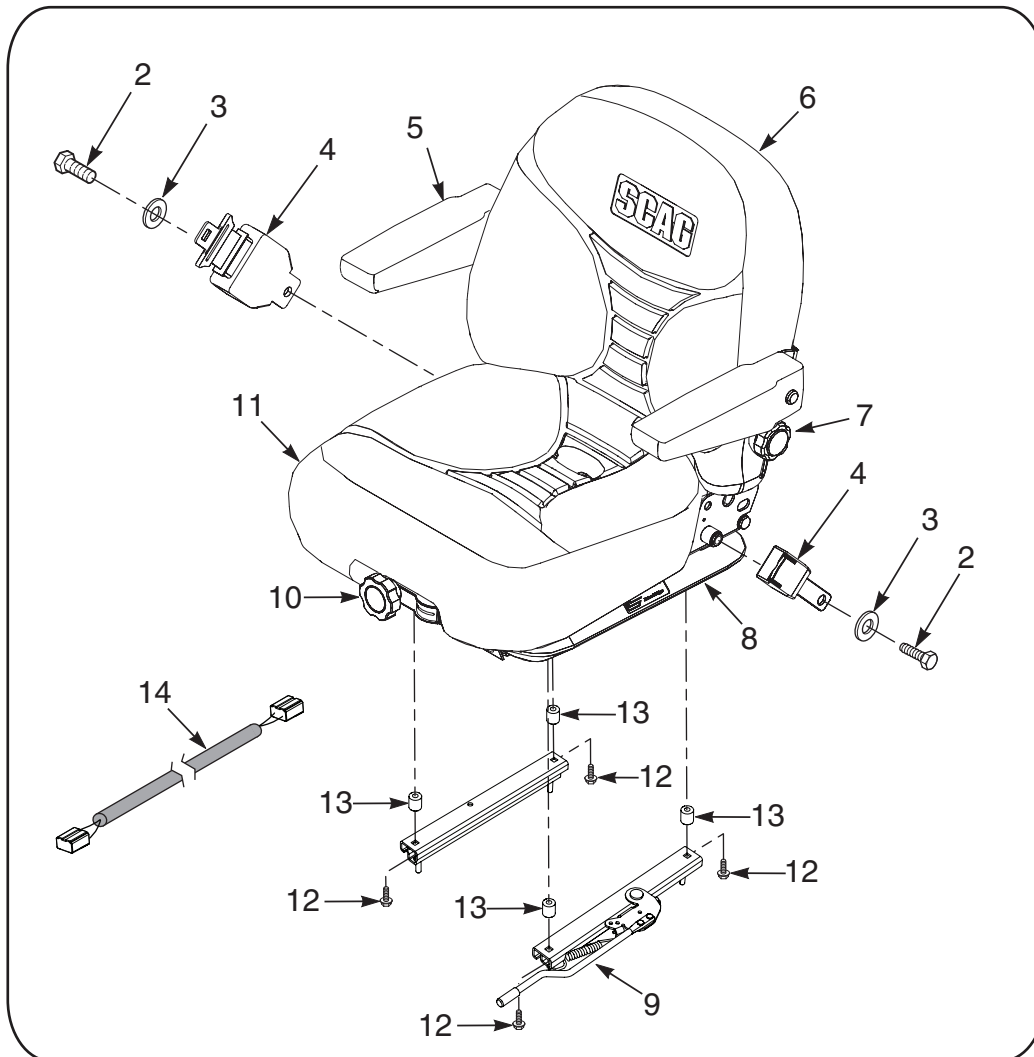

Ref. No.	Part No.	Description
1	9292	Suspension Seat Assembly w/seat belt
2	04001-178	Bolt, Hex Head 7/16-20 x 1"
3	04040-11	Flatwasher, 7/16-.500 x 1.25 x .083
4	483594	Retractable Seat Belt
5	482950	Armrest Only
	482945	Armrest Assembly Kit, LH
	482946	Armrest Assembly Kit, RH
6	482940	Back Cushion Kit
7	482943	Lumbar Kit
	482948	Knob Kit
8	482942	Shock Absorber Kit
9	482952	Seat Adjustment, Track Set
10	482944	Weight Adjustment Kit
	482948	Knob Kit
11	482941	Seat Cushion Kit
		Seat Drain Kit (Included with Seat Cushion)
12	04001-12	Bolt, Hex Head 5/16-18 x 1-3/4"
13	43572	Spacer
14	483440	Wire Harness Adapter

NOTES

DRIVE SYSTEM COMPONENTS

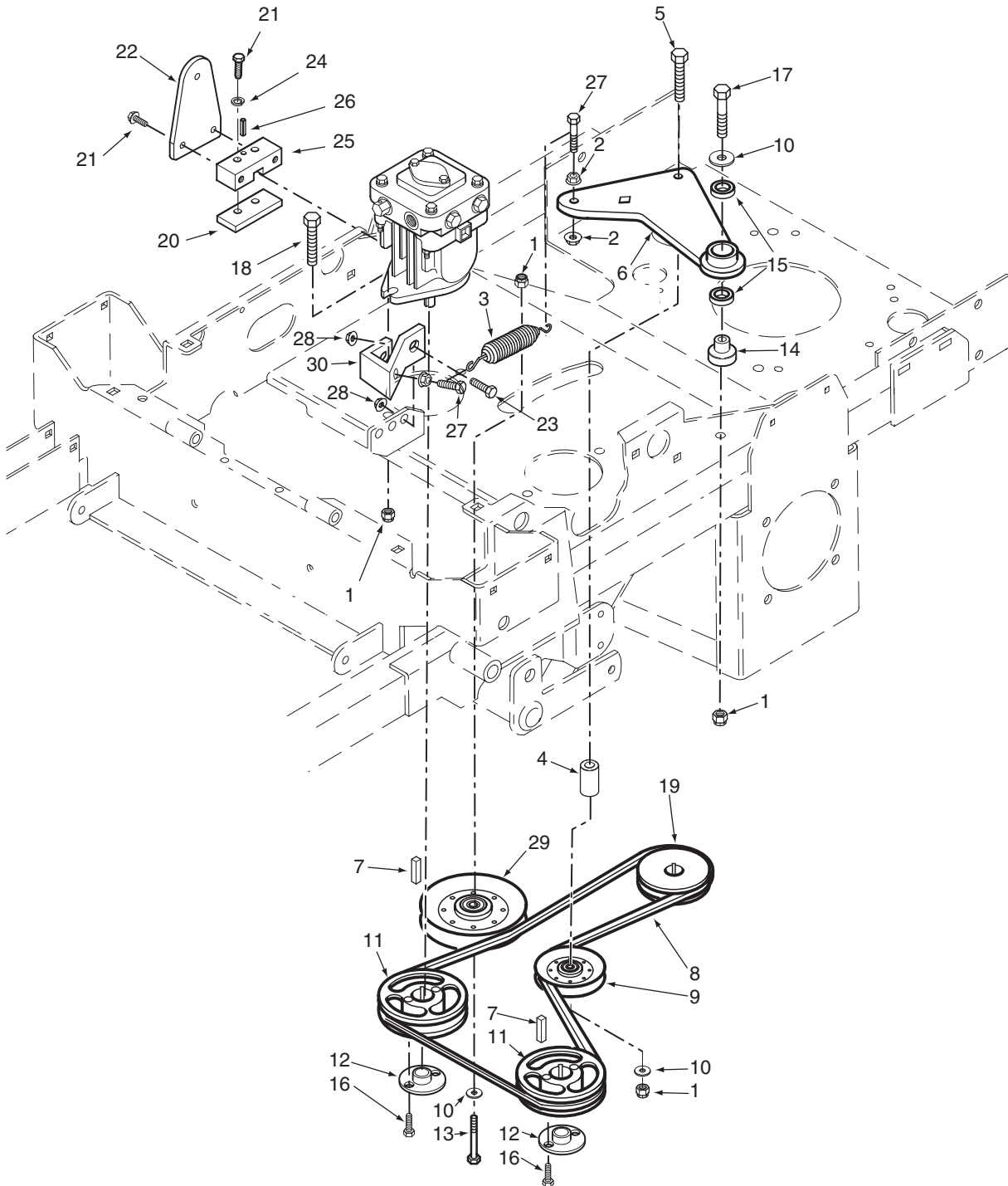

DRIVE SYSTEM COMPONENTS

Ref. No.	Part No.	Description
1	04021-09	Nut, Elastic Stop 3/8-16
2	04019-04	Nut, Serr. Flng. 3/8-16
3	483087	Spring, Pump Idler
4	43286	Spacer
5	04001-22	Bolt, Hex Hd. 3/8-16 x 2-3/4"
6	461603	Idler Arm Assy., Pump Drive
7	04063-14	Key, 5 x 5 x 25mm
8	483172	Belt, Transmission
9	483415	Pulley, 3-1/2" Dia. Idler
10	04043-04	Flatwasher, 3/8 (.391 x .938 x .105")
11	482744	Pulley, 5.75" OD Taper Bore
12	482085	Hub, Tapered, 15mm Bore
13	04001-45	Bolt, 3/8-16 x 2"
14	43503	Pivot, Idler
15	48224	Bearing
16	04001-172	Bolt, Hex Hd. 1/4-20 x 1" Grd. 8
17	04001-31	Bolt, Hex Hd. 3/8-16 x 2-1/2"
18	04001-20	Bolt, Hex Hd. 3/8-16 x 1-1/2"
19	483081	Pulley, 5.75" Dia. - 1.125" Bore
20	421203	Clamp Plate
21	04017-05	Hex Hd. Capscrew, 1/4-20 x 3/4"
22	422969	Control Lever, Pump
23	04001-19	Bolt, Hex Hd. 3/8-16 x 1"
24	04030-02	Lockwasher, 1/4"
25	48829	Block, Pump Control
26	04060-06	Roll Pin
27	04001-136	Bolt, Hex Hd. 3/8-16 x 1-1/2" Grd. 8
28	04019-04	Nut, Serr. Flng. 3/8-16
29	483215	Pulley, 5" Dia. Idler
30	424137	Bracket

ENGINE AND ATTACHING PARTS

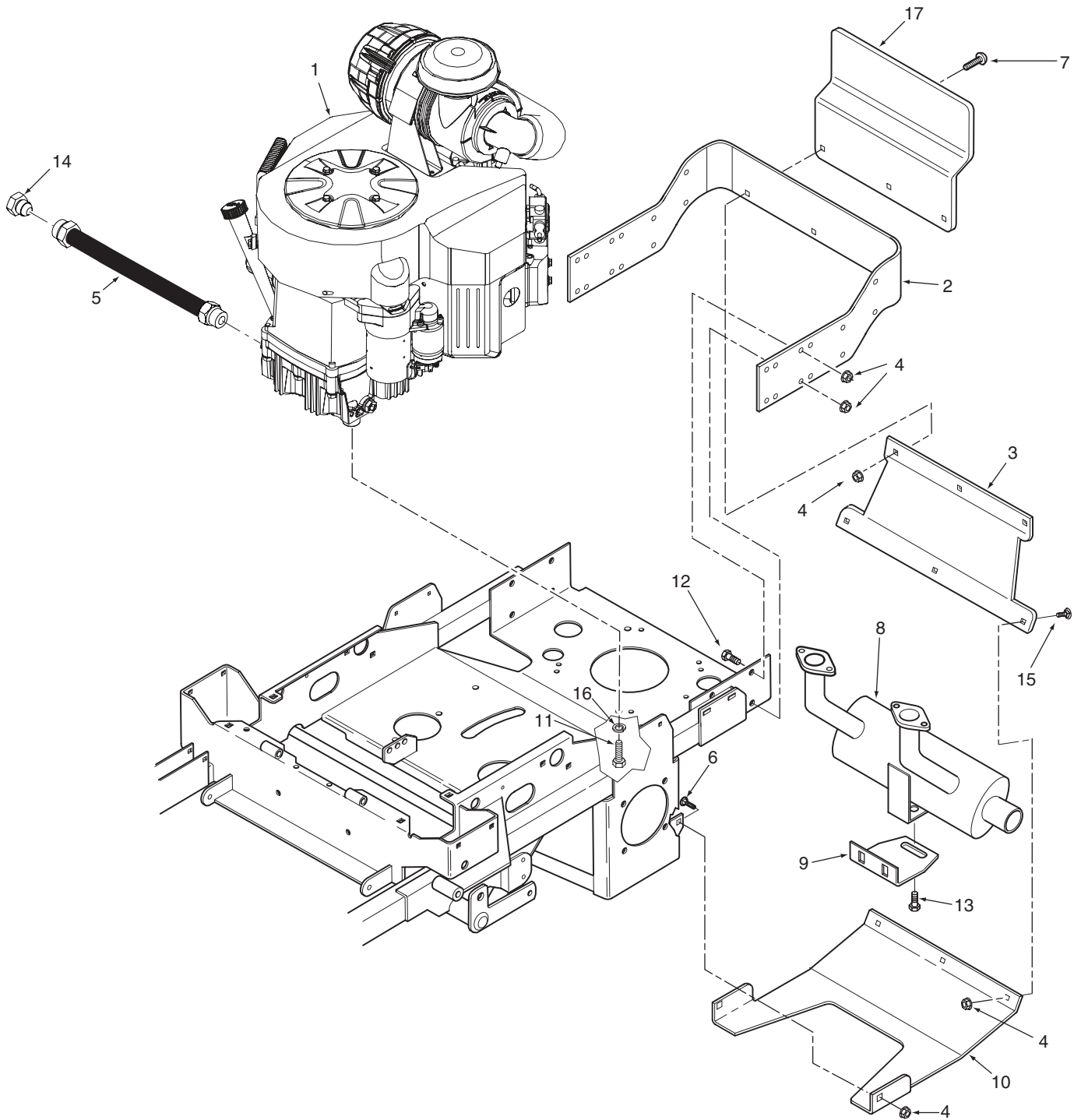

ENGINE AND ATTACHING PARTS

Ref. No.	Part No.	Description
1	484226	Engine, Kohler Command, 25hp
	484225	Engine, Kawasaki FX730V, 26hp
	484229	Engine, Kawasaki FD731V, 26hp
	484227	Engine, Kohler Command, 27hp
	423770	Bumper, Rear
2	424107	Shield, Rear (48" & 52")
3	41031	Weight, Rear Shield (61" Only)
4	04019-04	Nut, Serr. Flange 3/8-16
5	484304	Hose, Oil Drain - Kawasaki FX (incl. #14)
	484306	Hose, Oil Drain - Kohler CV (Incl. #14)
	484303	Hose, Oil Drain - Kawasaki Liquid-Cooled (incl. #14)
6	04003-23	Bolt, Carr. 3/8-16 x 1"
7	04104-01	Bolt, 3/8-16 x 1" Torx
8	483187	Muffler (Kawasaki Liquid-Cooled)
	483266	Muffler (Kohler)
	484209	Muffler (Kawasaki FX)
9	424133	Bracket, Muffler
10	423555	Plate, Skid
11	04001-32	Bolt, Hex Head 3/8-16 x 1-1/4" (Kawasaki)
	04011-07	Bolt, Hex Head 3/8-16 x 1-1/4" Self Tap (Briggs and Kohler)
	04001-11	Bolt, Hex Head 5/16-18 x 1-1/2" (Right Front Engine Mounting, Kohler Only)
	04019-03	Nut, Serrated Flange 5/16-18 (Right Front Engine Mounting, Kohler Only)
	04001-19	Bolt, Hex Head 3/8-16 x 1"
12	04011-12	Screw, Hex Head 5/16-18 x 3/4" Self Tap
13	48771-02	Plug, 3/4-16 JIC
14	04003-31	Bolt, Carr. 3/8-16 x 3/4"
15	04019-03	Nut, Serr. Flange 5/16-18
16	424415	Guard, Carb Inlet (Kawasaki Liquid-Cooled Only))
17		

STEERING COMPONENTS

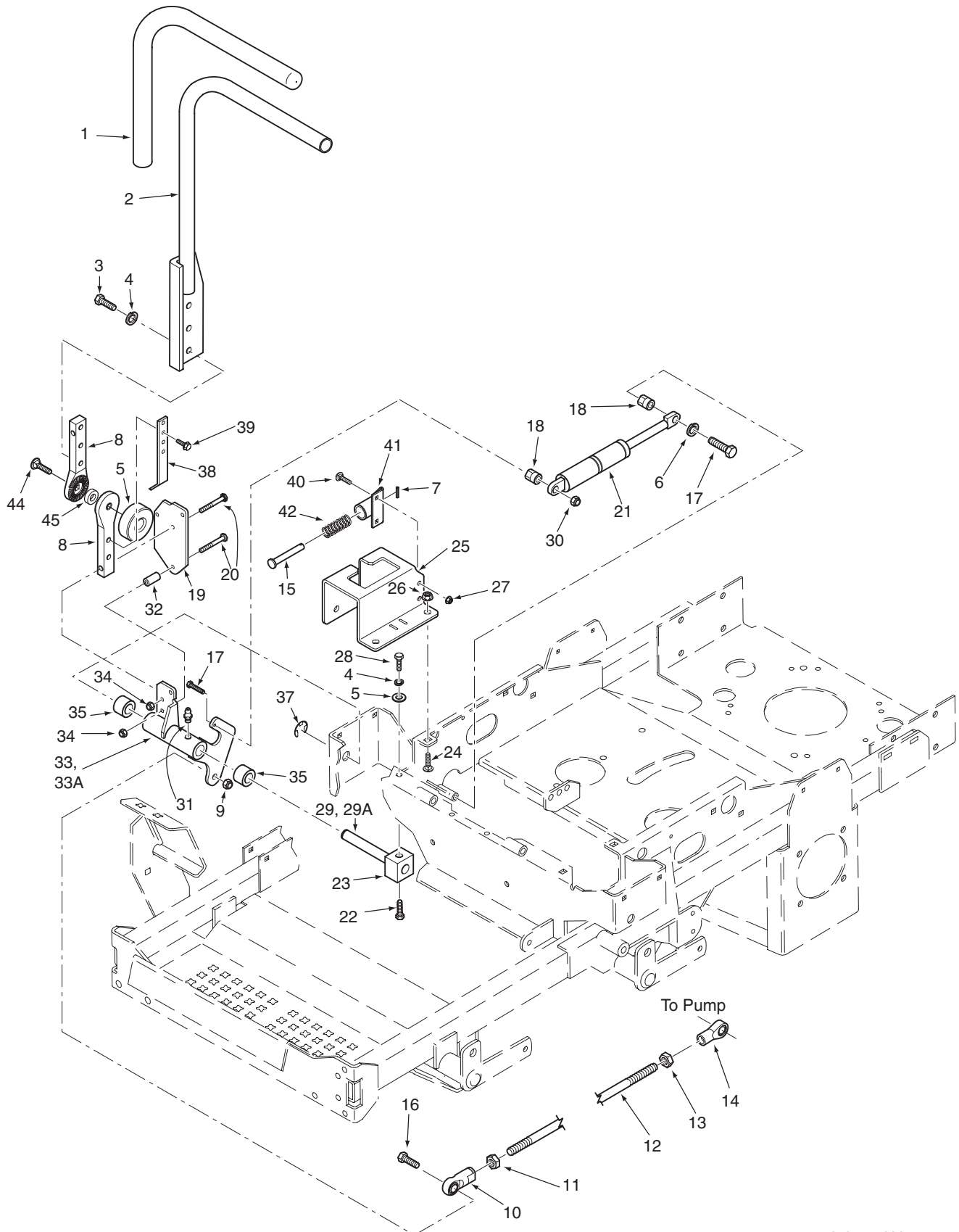

STEERING COMPONENTS

Ref. No.	Part No.	Description
1	482340	Grip, Control Lever
2	461914	Handle Bar, LH (Incl. item 1)
	461923	Handle Bar, RH (Incl. item 1)
3	04001-09	Bolt, Hex Hd. 5/16-18 x 1"
4	04030-03	Lockwasher, 5/16"
5	483269	Knob
6	04040-15	Flatwasher, 5/16 (.375 x .875 x .083")
7	04060-01	Roll Pin, Spring 5/32 x 3/4"
8	483238	Pivot, Control Lever
9	04021-09	Nut, Elastic Stop 3/8-16
10	482330	Rod End, 3/8-24 RH Female
11	04020-14	Nut, 3/8-24 RH Thread
12	482623	Rod, Pump Control Linkage
13	04020-17	Nut, 3/8-24 UNF-2B LH Thread
14	482331	Rod End, 3/8-24 LH Thread
15	43477	Pin Retainer
16	04001-20	Bolt, Hex Hd. 3/8-16 x 1-1/2"
17	04001-12	Bolt, Hex Hd. 5/16-18 x 1-3/4"
18	43602	Spacer, Pump Damper
19	423599	Plate, Control Lever
20	04001-17	Bolt, Hex Hd. 5/16-18 x 2"
21	484151	Gas Damper
22	04001-19	Bolt, Hex Hd. 3/8-16 x 1"
23	482099	Block, Clamping
24	04003-12	Bolt, Carriage, 5/16-18 x 3/4"
25	461770	Control Plate - LH w/Decal
	461771	Control Plate - RH w/Decal
26	04019-03	Nut, Serr., Flng., 5/16-18
27	04021-08	Nut, Elastic Stop 1/4-20
28	04001-18	Bolt, Hex Hd. 3/8-16 x 3/4"
29	43616	Shaft, Steering Control
30	04021-10	Nut, Elastic Stop 5/16-18
31	48114-04	Grease Fitting, 1/4-28 Self Tap
32	43559	Spacer, Control
33	49574	Control Lever Assy RH (Incl. 31 & 35)
	49573	Control Lever Assy LH (Incl. 31 & 35)
34	04021-10	Nut, Elastic Stop 5/16-18
35	48100-06	Bushing
36	04041-08	Flatwasher, 3/4 (.766 x 1.25 x .059")
37	04050-02	Retaining Ring, 3/4" Ext.
38	423057	Bracket, Switch Actuator
39	04017-16	Bolt, Hex Serr. Flng. 5/16-18 x 3/4"
40	04003-02	Bolt, Carr. 1/4-20 x 3/4"
41	45918	Bracket, Control Return
42	481389	Spring
43	43477	Pin Retainer
44	04003-38	Bolt, Carriage 5/16-18 x 1-1/2"
45	483250	Rubber Spacer

BRAKE COMPONENTS

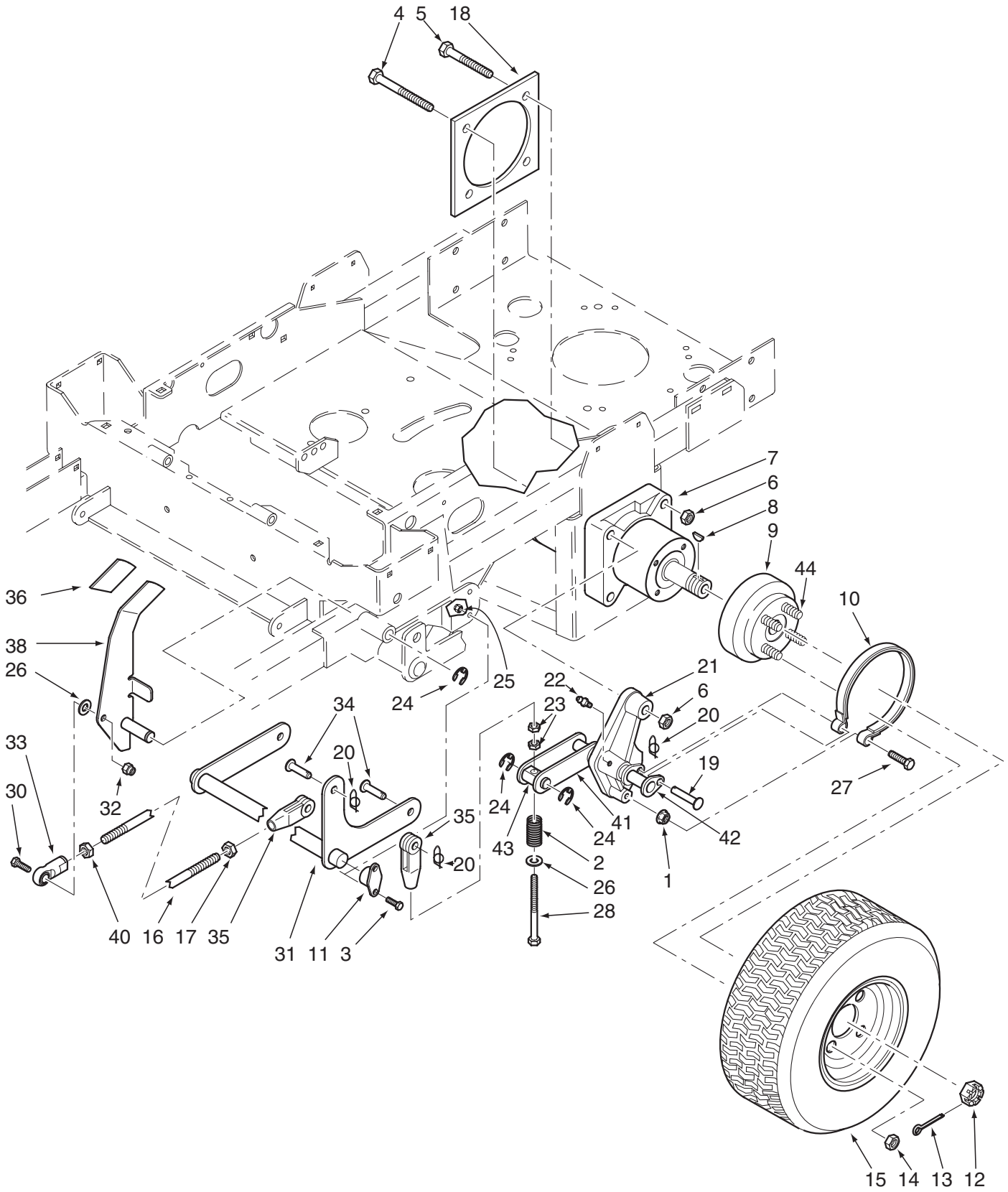

STC 2002 BSC

Section 8

BRAKE COMPONENTS

Ref. No.	Part No.	Description
1	04019-06	Nut, Serr. Flng. 1/2-13
2	48807	Spring
3	04001-08	Bolt, Hex Hd. 5/16-18 x 3/4"
4	04001-87	Bolt, Hex Hd. 1/2-13 x 4"
5	04001-52	Bolt, Hex Hd. 1/2-13 x 2-1/2"
6	04021-19	Nut, 1/2-13 Center Lock
7	482639	Wheel Motor, Parker
8	04063-25	Key, Woodruff 5/16 x 1"
9	461438	Wheel Hub Assembly
10	483644	Brake Band Assembly
11	482061	Bushing, Self Align
12	48680	Nut, Hex Castle 1.0-20 UNEF
13	04061-06	Cotter Pin, 9/64 x 1-1/2"
14	04028-02	Lug Nut, 1/2-20
15	484105	Wheel Assembly 24 x 9.5-12 (48" Cutter Deck)
	484106	Wheel Assembly 24 x 9.5-12 (52" Cutter Deck)
	481850	Wheel Assembly 24 x 12-12 (61" Cutter Deck)
	481659	Rim (48" Cutter Deck)
	482414	Rim (52" Cutter Deck)
	481851	Rim (61" Cutter Deck)
	484104	(48"/52") Tire 24 x 9.5 - 12
	481852	Tire 24 x 12 - 12
16	04004-46	Brake Rod Stud, 3/8-24 x 8-1/8"
17	04020-14	Nut, 3/8-24 UNF
18	423279	Plate Weldment, Motor Backing
19	04064-16	Clevis Pin, 3/8 x 1.93"
20	04069-01	Pin, Rue Cotter 3/8" Dia.
21	451970	Brake Linkage LH
	451971	Brake Linkage RH
22	48114-04	Grease Fitting, 1/4-28
23	04020-25	Nut, 3/8-24 UNF
24	04050-01	Retaining Ring, .625" Ext.
25	04021-10	Nut, Elastic Stop 5/16-18
26	04041-07	Flatwasher, 3/8 (.391 x .938 x .105")
27	04001-187	Bolt, Hex Hd. 1/2-13 x 2-1/2" Grd. 8
28	04001-166	Bolt, Hex Hd. 3/8-24 x 3-3/4"
29	04061-02	Cotter Pin, 3/32 x 3/4"
30	04001-20	Bolt, Hex Hd. 3/8-16 x 1-1/2"
31	451463	Brake Shaft
32	04021-09	Nut, Elastic Stop 3/8-16
33	48544	Rod End, 3/8-24 LH Thread
34	04064-02	Clevis Pin, 3/8 x 1.06"
35	48343-04	Clevis, 3/8-24
36	482102	Grip, Brake Lever
37	04019-04	Nut, Serr. Flng. 3/8-16
38	461509	Brake Lever (Incl. item 36)
39	04001-22	Bolt, Hex Hd. 3/8-16 x 2-3/4"
40	04020-17	Nut, 3/8-24 UNF-2B LH Thread
41	422483	Lever, Brake
42	45974	Shaft Weldment, Pivot
43	43495	Pin, Pivot
44	04008-01	Bolt, Serr. Flng. 1/2-20 x 4.563"

HYDRAULIC SYSTEM

Ref. No.	Part No.	Description
1	482643 482644	Pump, BDP-10A-316 (LH) Pump, BDP-10A-419 (RH)
2	482266-01	Elbow, 90 Degree 9/16" O-Ring x 3/8" Hose
3	48572-02	Fitting, 1/2" JIC x 5/8" O-Ring
4	48811	Hose, 3/8" Pushlock (Specify length)
5	482573	Bushing
6	482574	Fitting
7	482266-01	Elbow, 90 Degree 9/16" O-Ring x 3/8" Hose
8	48136-13	Hose Clamp, .69" Dia.
9	482548	Hose Assembly
10	04060-06	Roll Pin
11	48572-04	Fitting, 1/2" JIC x 1/2" O-Ring
12	48603-06	O-Ring
13	04001-20	Bolt, Hex Head 3/8-16 x 1-1/2"
14	04017-07	Bolt, Hex Head 1/4-20 x 1-1/4"
15	04030-02	Lockwasher
16	04021-09	Nut, Elastic Stop 3/8-16
17	422969	Control Lever
18	04001-08	Bolt, Hex Head 5/16-18 x 3/4"
19	04030-03	Lockwasher, 5/16"
20	04040-15	Flatwasher, 5/16-.375 x .875 x .083
21	481164	Cap, Hydraulic Tank
22	481507	Insert, Filler Neck
23	48829	Control Block
24	421203	Clamp Plate
25	461479	Hydraulic Tank Assembly w/Fittings
26	48603-06	O-Ring, 9/16"
27	482277	Tee Fitting, O-Ring to Barb
28	48136-13	Clamp, .69" Max. / .25" Min. Dia.
29	482571	Bushing
30	482572	Elbow, 0.38" Hose
31	48136-13	Clamp
32	482639	Wheel Motor, Parker
33	48603-02	O-Ring, 3/4"
34	482802	Nipple, Oil Filter 1.0-12 UNF-2A x 1-1/4"
35	04001-11	Bolt, Hex Head 5/16-18 x 1-1/2"

Ref. No.	Part No.	Description
36	48136-13	Clamp, .69" Max. / .25" Min. Dia.
37	482800-02	Fitting, 9/16" O-Ring x 3/8" Hose
38	04019-03	Nut, Serr. Flange 5/16-18
39	04041-07	Flatwasher, 3/8-.391 x .938 x .105"
40	48462-01	Oil Filter
41	482798	Filter Head Assembly
42	482800-01	Fitting, 3/4" O-Ring x 3/8" Hose
43	48604-03	Plug, 9/16-18 O-Ring
44	482557	Hose, Filter Inlet
45	482605	Hose Assembly
46	48811	Hose, 3/8" Pushlock 15" Long
47	04001-17	Bolt, Hex Head 5/16-18 x 2"
48	482708	Cooler, Transmission

** Available through the individual engine manufacturer.

STWC FUEL SYSTEM - EPA PHASE 2 (models produced prior to 1/1/2011)

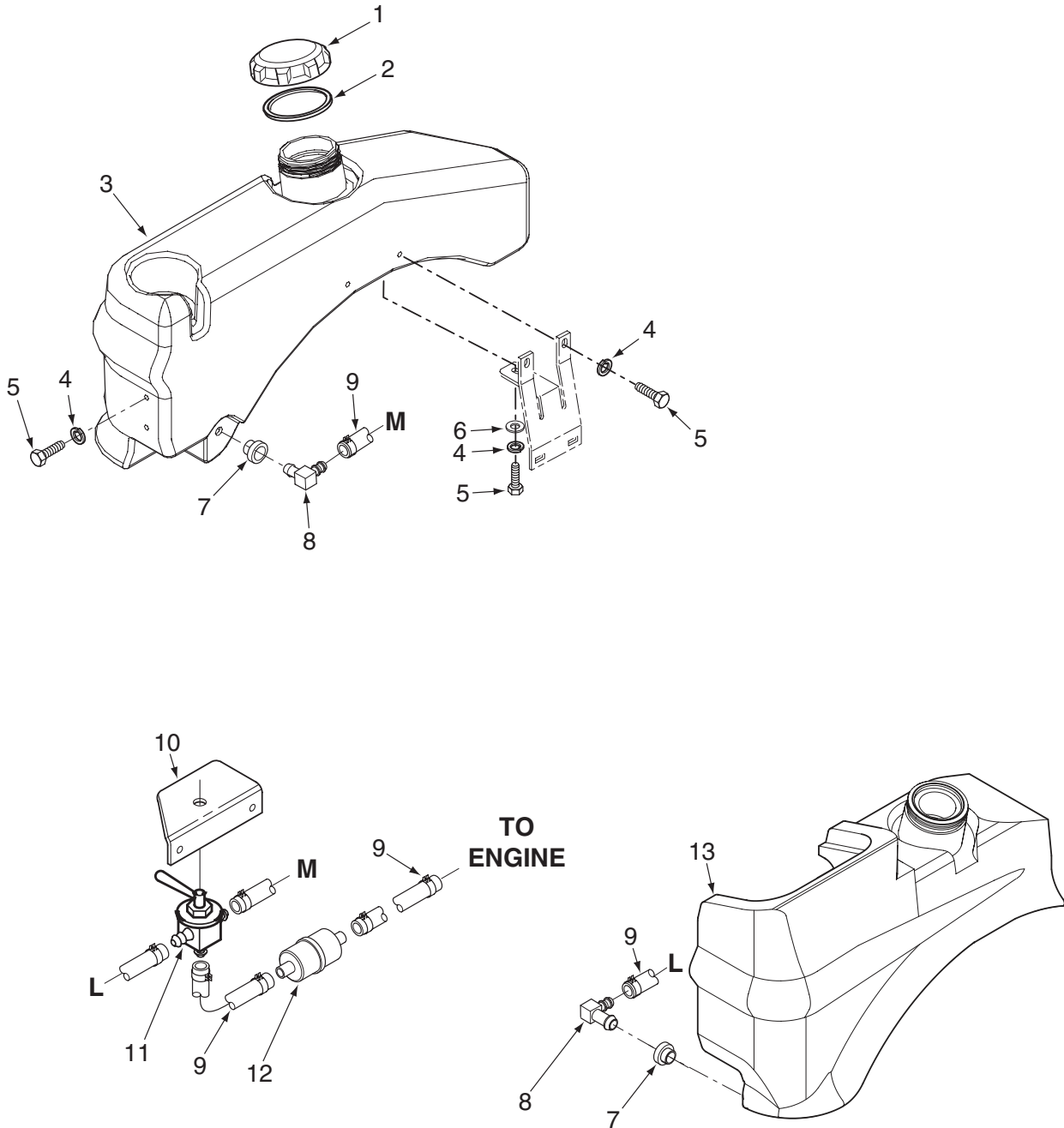

STC 2011 FS EPA PHASE 2

**STWC FUEL SYSTEM - EPA PHASE 2
(models produced prior to 1/1/2011)**

Ref. No.	Part No.	Description
1	483792	Fuel Cap
2	482774	Gasket, Fuel Cap
3	462163	Fuel Tank RH (incl. #7 & #8)
4	04030-03	Lockwasher, 5/16" Spring
5	04001-08	Bolt, Hex Head 5/16-18 x 3/4"
6	04040-15	Flatwasher, 5/16-.375 x .875 x .083
7	482571	Tank Bushing
8	483748	Fitting, 90 Degree
9	483617	Fuel Hose, 1/4" I.D. Non-Perm (order by inch)
10	423912	Bracket, Fuel Valve
11	482212	Fuel Shutoff Valve
12	*	Fuel Filter
13	462162	Fuel Tank LH (incl. #7 & #8)

* = Available through engine manufacturer only.

STWC FUEL SYSTEM - EPA PHASE 3 (models produced after 1/1/2011)

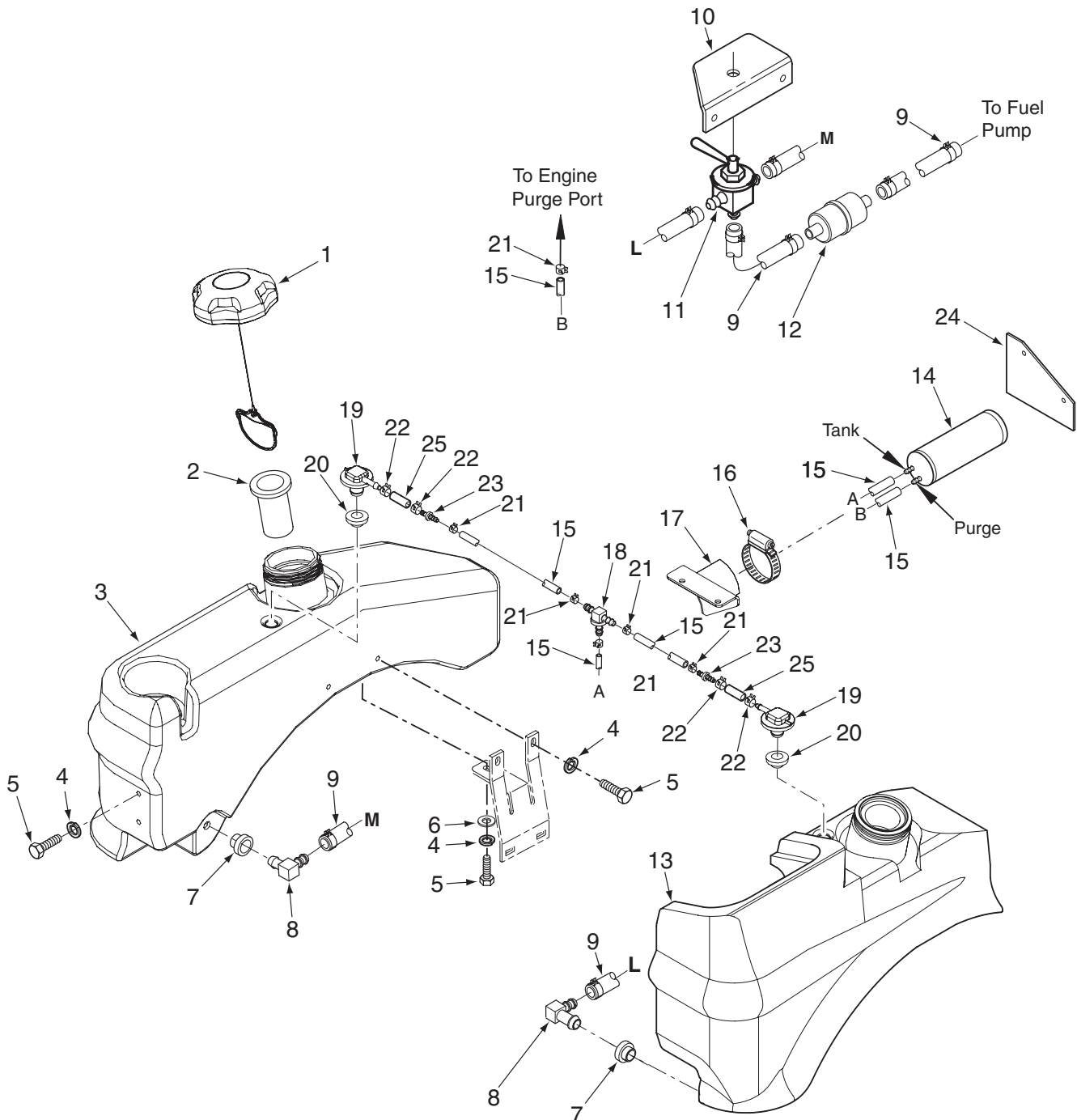

**STWC FUEL SYSTEM - EPA PHASE 3
(models produced after 1/1/2011)**

Ref. No.	Part No.	Description
1	484286	Fuel Cap w/ Tethered
2	484279-01	Tube, Fuel Tank Insert
3	462298	Fuel Tank RH (incl. #7 & #8)
4	04030-03	Lockwasher, 5/16" Spring
5	04001-08	Bolt, Hex Head 5/16-18 x 3/4"
6	04040-15	Flatwasher, 5/16-.375 x .875 x .083
7	482571	Tank Bushing
8	483748	Fitting, 90 Degree
9	483617	Fuel Hose, 1/4" I.D. Non-Perm (order by inch)
10	423912	Bracket, Fuel Valve
11	482212	Fuel Shutoff Valve
12	*	Fuel Filter
13	462297	Fuel Tank LH (incl. #7 & #8)
14	484342	Carbon Canister
15	484347	Hose, 3/16" (order by inch)
16	48136-17	Clamp
17	452176	Bracket, Canister Mounting
18	48935-02	T - Fitting, Fuel Vent
19	484284	Valve, Rollover
20	484285	Grommet, Viton
21	48059-05	Clamp, Vapor Recovery Hose 3/16"
22	48059-02	Clamp, Fuel Hose
23	484343-01	Mender, 1/4 x 3/16 w/.02 Hole
24	425559	Heatshield
25	484347	Hose, 1/4" Vapor Recovery (order by inch)

* = Available through engine manufacturer only.

ELECTRICAL SYSTEM - KOHLER & KAWASAKI AIR-COOLED

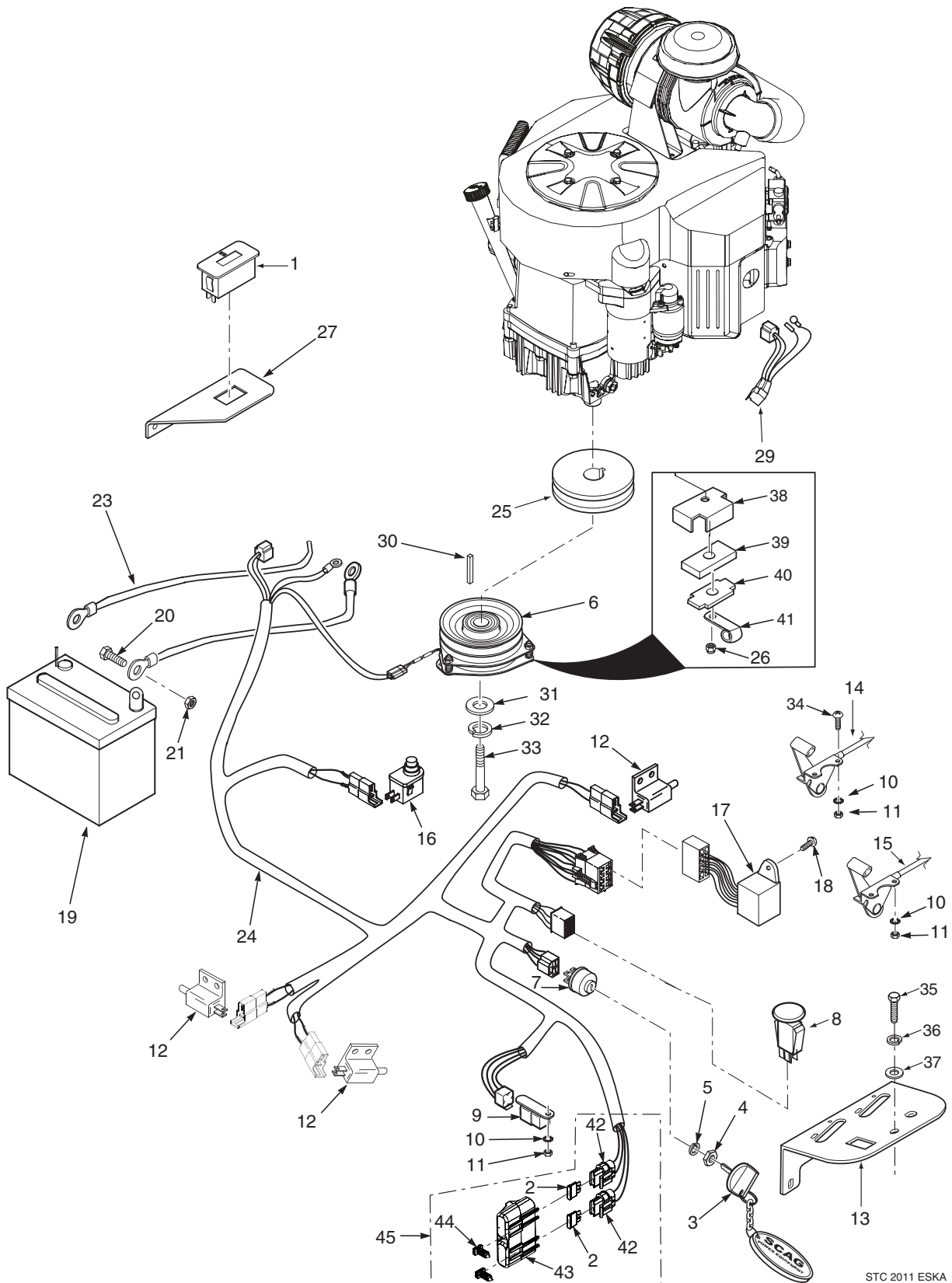

STC 2011 ESKA

ELECTRICAL SYSTEM - KOHLER & KAWASAKI AIR-COOLED

Ref. No.	Part No.	Description
1	483537	Hourmeter
2	48298	Fuse, 20 amp
3	483366	Key, Ignition
	462069	Key Assembly w/Fob
4	48017-04	Nut, Hex 5/8-32
5	48017-03	Lockwasher, 5/8" Internal
6	461660	Electric PTO Clutch GT3.5
7	48798	Switch, Ignition
8	483957	Switch, PTO
9	483013	Relay
10	04031-01	Lockwasher, #10 External Tooth
11	04020-01	Nut, Hex #10-32
12	481637	Switch, N/O
13	461768	Panel, Instrument
14	482032	Choke & Throttle Control - Kawasaki (Qty 2)
	481544	Choke Control - Kohler (Qty 1)
15	482032	Throttle Control - Kohler (Qty 1)
16	481638	Switch, Seat
17	483599	Module, Interlock
18	04010-01	Screw, #10-32 x .5" Phillips Head
19	483665	Battery, 350CCA (Not Available Through Scag)
20	04001-44	Bolt, Hex Head 1/4-20 x .5"
21	04020-02	Nut, Hex 1/4-20
22	48029-15	Cable, Battery Black (negative)
23	48029-12	Cable, Battery Red (positive)
24	483618	Wiring Harness, Main (Briggs & Stratton, Kohler)
	484178	Wire Harness, Main (Kawasaki)
25	483081	Pulley, 5.45 OD x 1.125" Bore
26	04021-10	Nut, Elastic Stop 5/16-18 Key
27	424112	Mounting Bracket, Hour Meter
28	04010-11	Screw, #10-32 x 1.5" Phillips Head
29	484179	Adapter, Wiring Harness (Kawasaki FX only)
	484078	Adapter, Wiring Harness (Kohler only)
30	04063-23	Key, 1/4 x 1/4 x 3-1/4"
31	04041-28	Flatwasher, 7/16-.469 x 1-3/4" x 1/4"
32	04030-05	Lockwasher, 7/16"
33	04001-101	Bolt, Hex Head 7/16-20 x 2-1/2" UNF
34	04010-12	Screw, #10-32 x 3/4"
35	04001-08	Bolt, Hex Head 5/16-18 x 3/4"
36	04030-03	Lockwasher, 5/16"
37	04040-15	Flatwasher, 5/16-.375 x .875 x .083
38	423909	Backing Plate
39	481716	Rubber Pad, Clutch Stop
40	422534	Plate, Backing
41	48030-09	Clamp
42	483629	Fuse Holder
43	483571	Cover, Sealed Double
44	482588	Clip, Wire
45	483642	Double Fuse Assembly, Sealed (Incl. items 2, 42, 43, 44)

ELECTRICAL SYSTEM - 26HP KAWASAKI LIQUID-COOLED

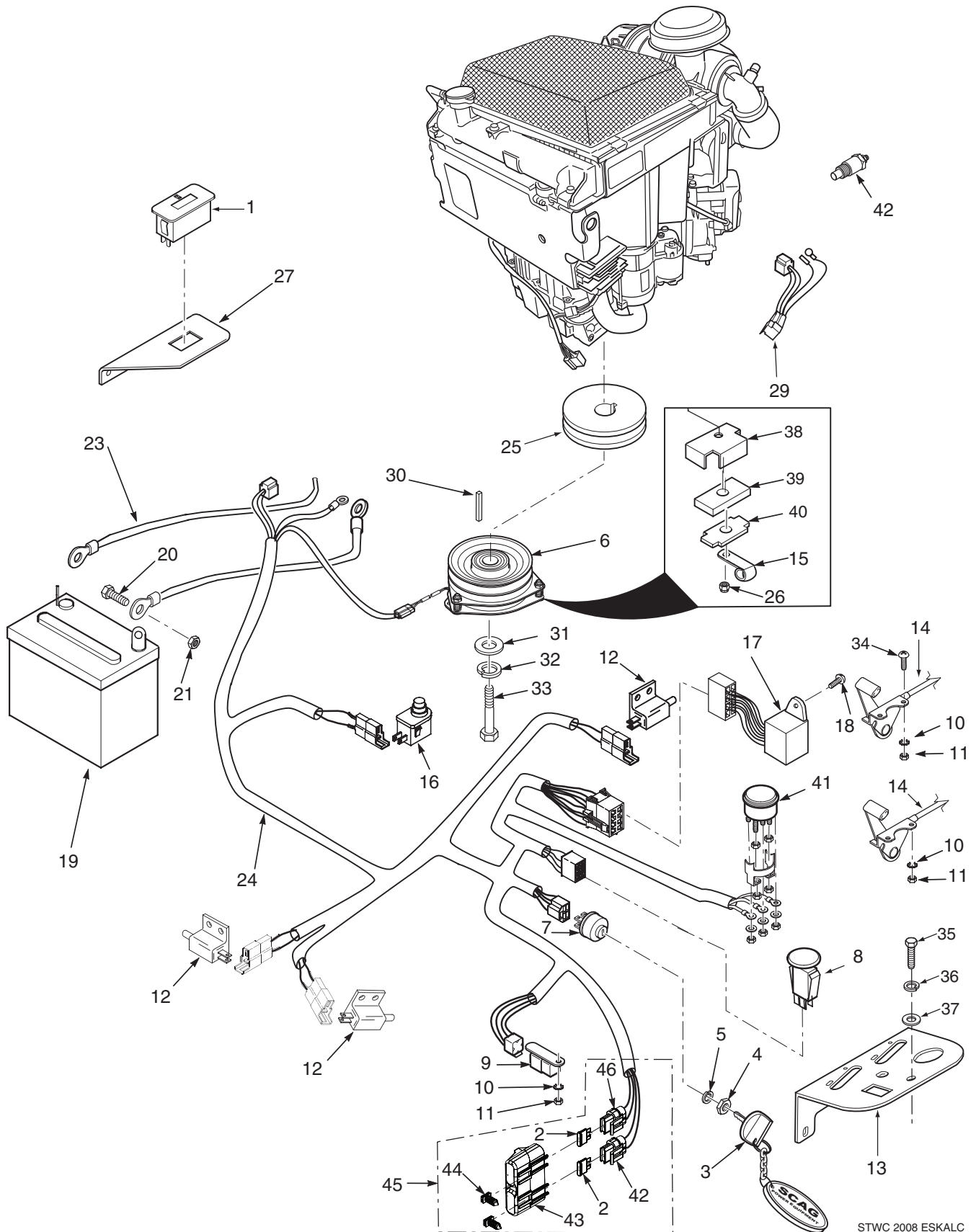

ELECTRICAL SYSTEM 26HP KAWASAKI LIQUID-COOLED

Ref. No.	Part No.	Description
1	483355	Hourmeter
2	48298	Fuse, 20 amp
3	483366	Key, Ignition
	462069	Key Assembly w/Fob
4	48017-04	Nut, Hex 5/8-32
5	48017-03	Lockwasher, 5/8" Internal
6	461660	Electric PTO Clutch GT3.5
7	48798	Switch, Ignition
8	483957	Switch, PTO
9	48788	Relay
10	04031-01	Lockwasher, #10 External Tooth
11	04020-01	Nut, Hex #10-32
12	481637	Switch, N/O
13	461952	Panel, Instrument
14	482032	Choke & Throttle Control - Kawasaki (Qty 2)
15	48030-09	Clamp
16	481638	Switch, Seat
17	483029	Module, Interlock
18	04010-01	Screw, #10-32 x .5" Phillips Head
19	**	Battery (Not Available Through Scag)
20	04001-44	Bolt, Hex Hd. 1/4-20 x .5"
21	04020-02	Nut, Hex 1/4-20
22	48029-15	Cable, Battery Black (negative)
23	48029-12	Cable, Battery Red (positive)
24	483619	Wiring Harness, Main
25	483081	Pulley, 5.45" OD x 1.125" Bore
26	04021-10	Nut, Elastic Stop 5/16-18 Key
27	424112	Mounting Bracket, Hour Meter
28	04010-11	Screw, #10-32 x 1.5" Phillips Head
29	483272	Adaptor, Wiring Harness
30	04063-23	Key, 1/4 x 1/4 x 3-1/4"
31	04041-28	Flatwasher, 7/16 (.469 x 1-3/4" x 1/4")
32	04030-05	Lockwasher, 7/16"
33	04102-03	Bolt, Hex Hd. 7/16-20 x 2-1/4" UNF (61A Only)
34	04010-12	Screw, #10-32 x 3/4"
35	04001-08	Bolt, Hex Hd. 5/16-18 x 3/4"
36	04030-03	Lockwasher, 5/16"
37	04040-15	Flatwasher, 5/16 (.375 x .875 x .083")
38	423909	Backing Plate
39	481716	Rubber Pad, Clutch Stop
40	422534	Plate, Backing
41	481183	Water Temp. Gauge
42	481670	Sender Unit, Water Temp
43	483571	Cover, Sealed Double
44	482588	Clip, Wire
45	483642	Double Fuse Assembly, Sealed (incl. items 2, 43, 44, 46)
46	483629	Fuse Holder

HYDRAULIC PUMP ASSEMBLY

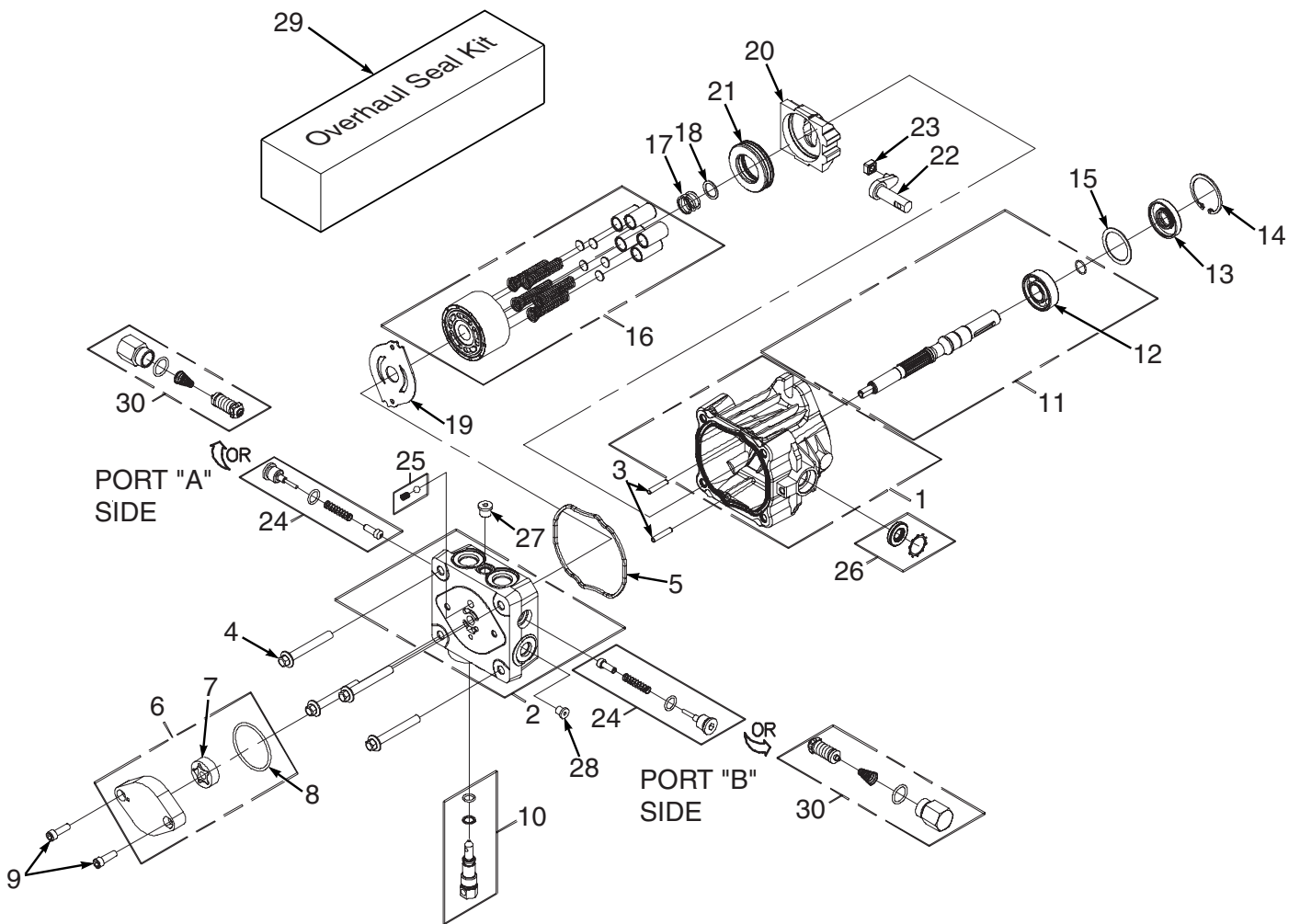

HYDRAULIC PUMP ASSEMBLY

Ref. No.	Part No.	Description
1	HG 70516	Housing Kit
2	HG 70573	End Cap Kit
3	HG 50641	Straight Headless Pin
4	HG 50969	Hex Flng. Bolt, M8-1.25 x 60mm
5	HG 51232	Housing O-Ring
6	HG 2513027	Charge Pump Kit
7	HG 50273	Gerotor Assembly
8	HG 9004101-1340	O-Ring
9	HG 50095	Socket Head Screw, M6 x 1.0-20mm
10	HG 2513030	Bypass Valve Kit
11	HG 70521	Pumpshaft Kit
12	HG 50315	Ball Bearing, 17 x 40 x 12mm
13	HG 51161	Lip Seal
14	HG 50329	Retaining Ring
15	HG 50951	Spacer
16	HG 70331	Cylinder Block Kit
17	HG 2003014	Block Spring
18	HG 2003017	Block Thrust Washer
19	HG 51444	Valve Plate
20	HG 2003087	Swash Plate
21	HG 50551	Ball Thrust Bearing
22	HG 2003005	Trunnion Arm
23	HG 2000015	Slot Guide
24	HG 2510062	Check Valve Kit (.024" Orifice) port "A" on Left Hand Pump, port "B" on Right Hand Pump
25	HG 70403	Charge Relief Kit
26	HG 2513043	Trunnion Seal with Retainer
27	HG 9005110-4400	Straight Thread Plug
28	HG 50408	Straight Headless Pin
29	HG 70525	Overhaul Seal Kit
30	HG 70743	System Check Relief Kit, port "B" on Left Hand Pump, port "A" on Right Hand Pump

* Common hardware which should be purchased locally. All bolts Grade 5 plated, all other fasteners zinc plated.

REPLACEMENT DECALS AND INFORMATION PLATES

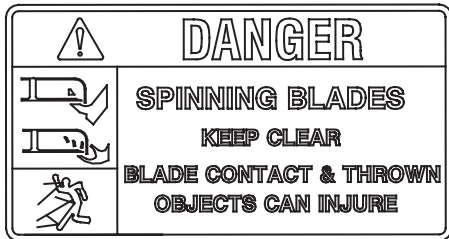

1

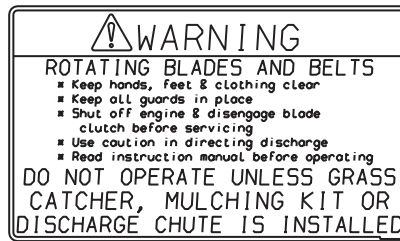

2



8

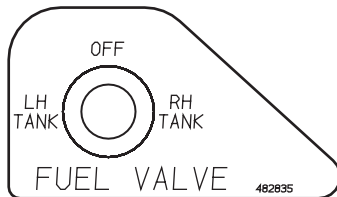

11

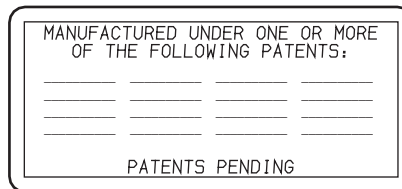

5



13



482100

6



481971

7

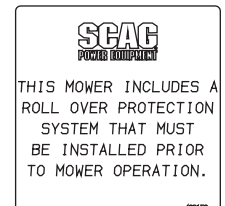

4



9

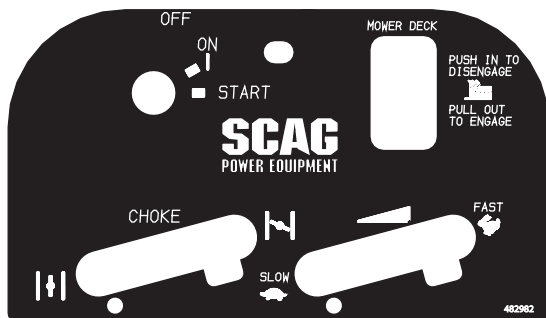

482982

10

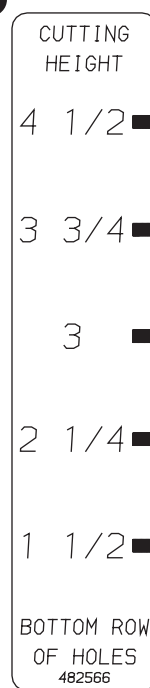

12

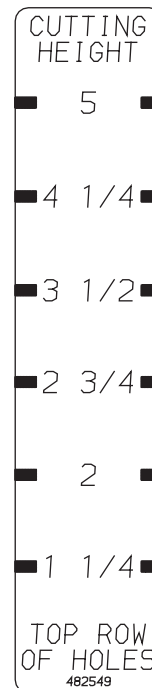

18



19

REPLACEMENT DECALS AND INFORMATION PLATES

Ref. No.	Part No.	Description
1	483407	Decal, Danger-Spinning Blades
2	483406	Decal, Warning-Rotating Blades
3	483199	Decal, 48V
	483200	Decal, 52V
	483201	Decal, 61V
4	483158	Decal, ROPS
5	483044	Decal, Patents
6	482100	Decal, Traction Control
7	481971	Decal, Heavy Duty Commercial
8	48404	Decal, Metalcraft - Made in USA
9	483402	Decal, Belt Cover
10	482982	Decal, Instrument Panel
11	482835	Decal, Fuel Valve Position
12	482566	Decal, Cutting Height Bottom Row of Holes
13	482906	Decal, Wildcat
14	482709	Decal, Seat Support
15	482905	Decal, Rear Bumper
16	482166	Decal, Front Footplate
17	483405	Decal, Discharge Chute
18	482549	Decal, Cutting Height Top Row of Holes
19	483425	Decal, ROPS
**	461983	Spanish Decal Kit, STC / STWC (not shown)
**	01411	DVD Video, Tips for Safe Operation of Your Scag Zero-Turn Mower

IMPORTANT ADJUSTMENT PROCEDURES
 READ OPERATOR'S MANUAL FOR MORE DETAILS
 Check tire pressure - (Drive tires-12 psi)
 - (Caster tires-25 psi)

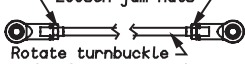
NEUTRAL ADJUSTMENT
 Loosen jam nuts

 Rotate turnbuckle

With an operator in the seat, engine running, control lever in neutral and the parking brake disengaged - adjust control linkage. Loosen jam nuts. If wheel rotates forward, adjust turnbuckle CW. If wheel rotates rearward, adjust turnbuckle CCW. Adjust until drive wheel stops turning. Tighten jam nuts. Repeat procedure until proper Neutral Adjustment is obtained.

TRACKING ADJUSTMENT
 If the machine pulls to the right, adjust LH control linkage CW to slow left wheel. If the machine pulls to the left adjust RH control linkage CW to slow right wheel. Readjust neutral if necessary.

FREE WHEEL OPERATION
 To move machine without running the engine, rotate both dump valves located at the LH side of the pumps CW 1/2 turn to "freewheel" positions. Return dump valves to original position to operate the mower. Tighten to 7-10 ft-lbs.

HYDRAULIC FLUID LEVEL
 Check hydraulic fluid level while fluid is cool. Fluid level should be 3" below top of filler neck. Fill with SAE 20W50 motor oil only.

IMPORTANT
 Do not overfill. Room for hot fluid expansion must be allowed or resulting expansion may cause leaks in the system.

482709

14

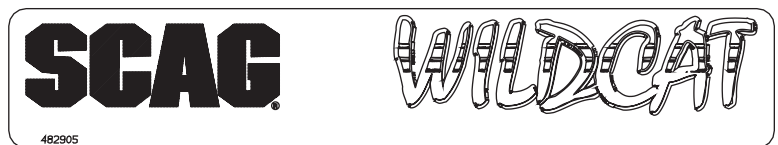

15



3



16



17

ELECTRICAL SCHEMATIC - KOHLER AIR-COOLED

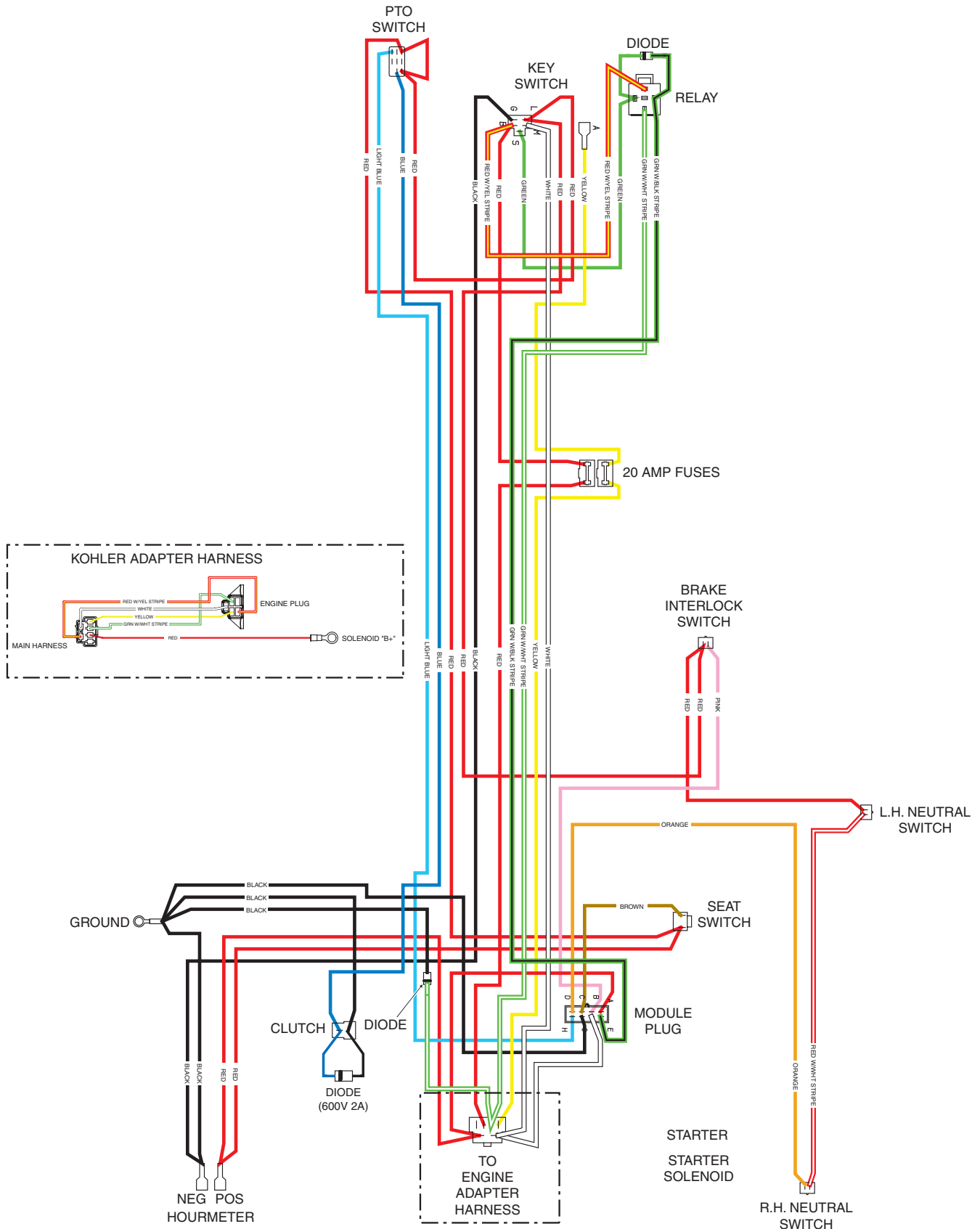

ELECTRICAL SCHEMATIC - KAWASAKI AIR-COOLED

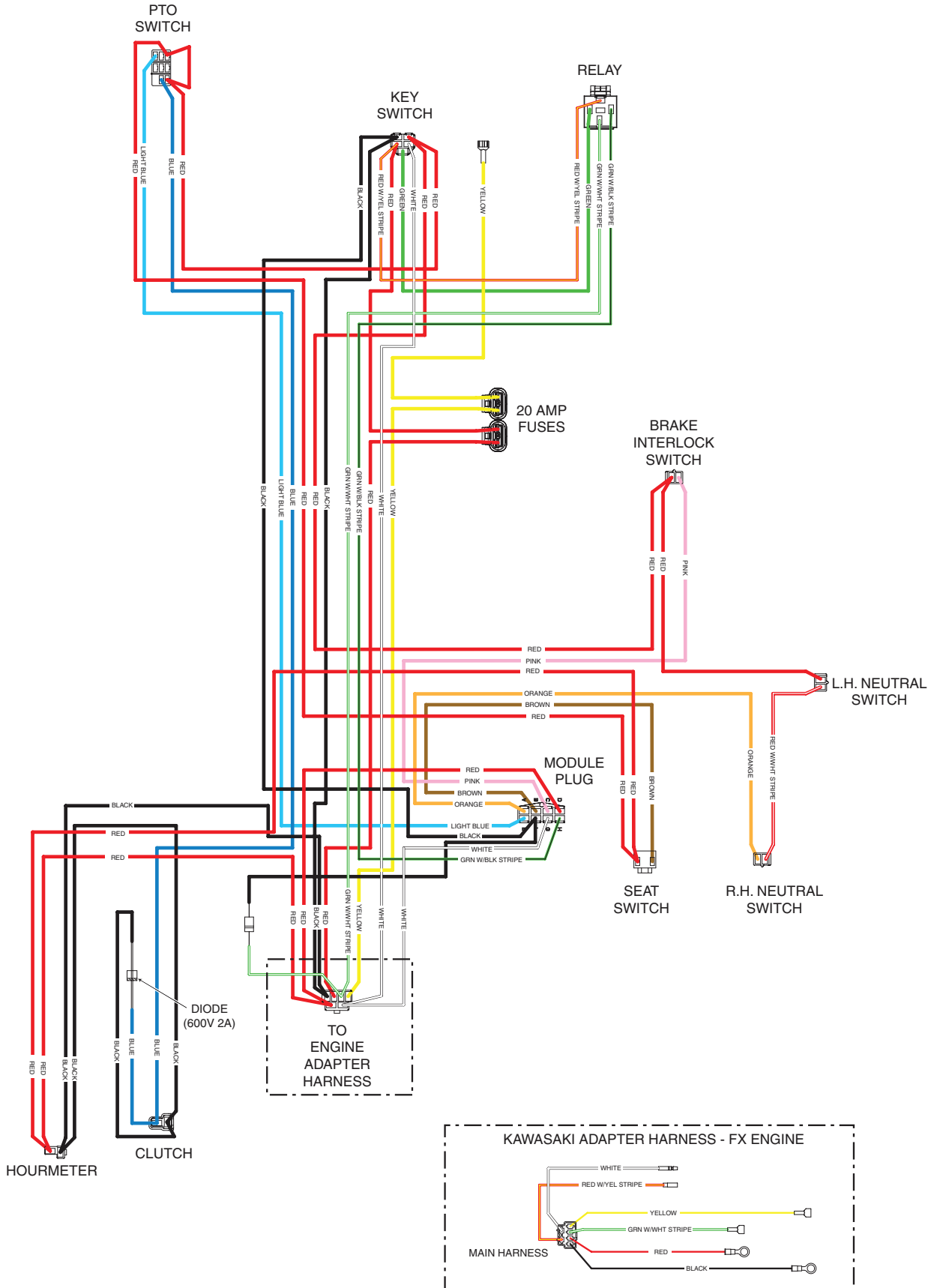

ELECTRICAL SCHEMATIC - 26HP KAWASAKI LIQUID-COOLED

