

SCAG[®]

POWER EQUIPMENT

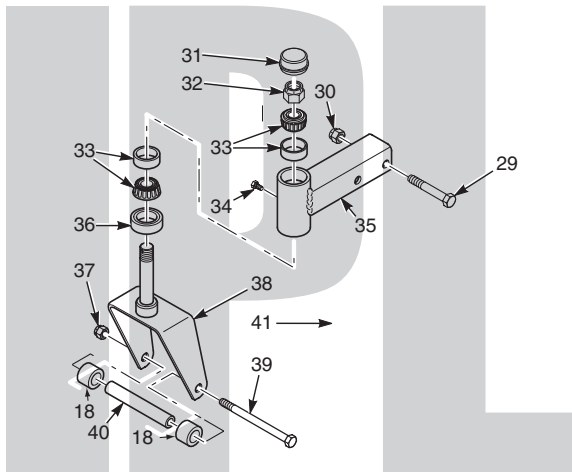

ILLUSTRATED PARTS MANUAL



Model SCZ48/52 Cheetah

THIS MANUAL CONTAINS THE ILLUSTRATED PARTS LIST FOR MODELS:

SCZ48V-691FX
SCZ48V-25CV
SCZ48V-28BS
SCZ52V-730FX
SCZ52V-27CV
SCZ52V-27CV-EFI
SCZ52V-28BS

with a serial number of H6700001 to H6799999
with a serial number of H6800001 to H6899999
with a serial number of H6900001 to H6999999
with a serial number of H7000001 to H7099999
with a serial number of H7100001 to H7199999
with a serial number of J3800001 to J3899999
with a serial number of H7200001 to H7299999

Table of Contents

48V & 52V CUTTER DECKS	2
CUTTER DECK CONTROLS	4
SHEET METAL COMPONENTS	6
SCZ ROLL-OVER PROTECTION SYSTEM.....	8
SCZ SEAT ASSEMBLY	10
NOTES.....	11
SCZ SUSPENSION SYSTEM	12
SCZ SUSPENSION SYSTEM	14
SCZ STEERING & FOOT PLATFORM COMPONENTS.....	16
SCZ STEERING COMPONENTS.....	18
SCZ DRIVE SYSTEM COMPONENTS	20
SCZ BRAKE COMPONENTS	22
SCZ HYDRAULIC SYSTEM	24
SCZ FUEL SYSTEM.....	26
SCZ ENGINE & ATTACHING PARTS	28
ZT-3400 TRANSAXLE ASSEMBLY.....	30
SCZ ELECTRICAL SYSTEM	32
SCZ ELECTRICAL SYSTEM	34
SCZ EFI ELECTRICAL SYSTEM.....	36
REPLACEMENT DECALS AND INFORMATION PLATES	38
SCZ ELECTRICAL SCHEMATIC	40
SCZ ELECTRICAL SCHEMATIC	41
SCZ EFI ELECTRICAL SCHEMATIC	42

48V & 52V CUTTER DECKS

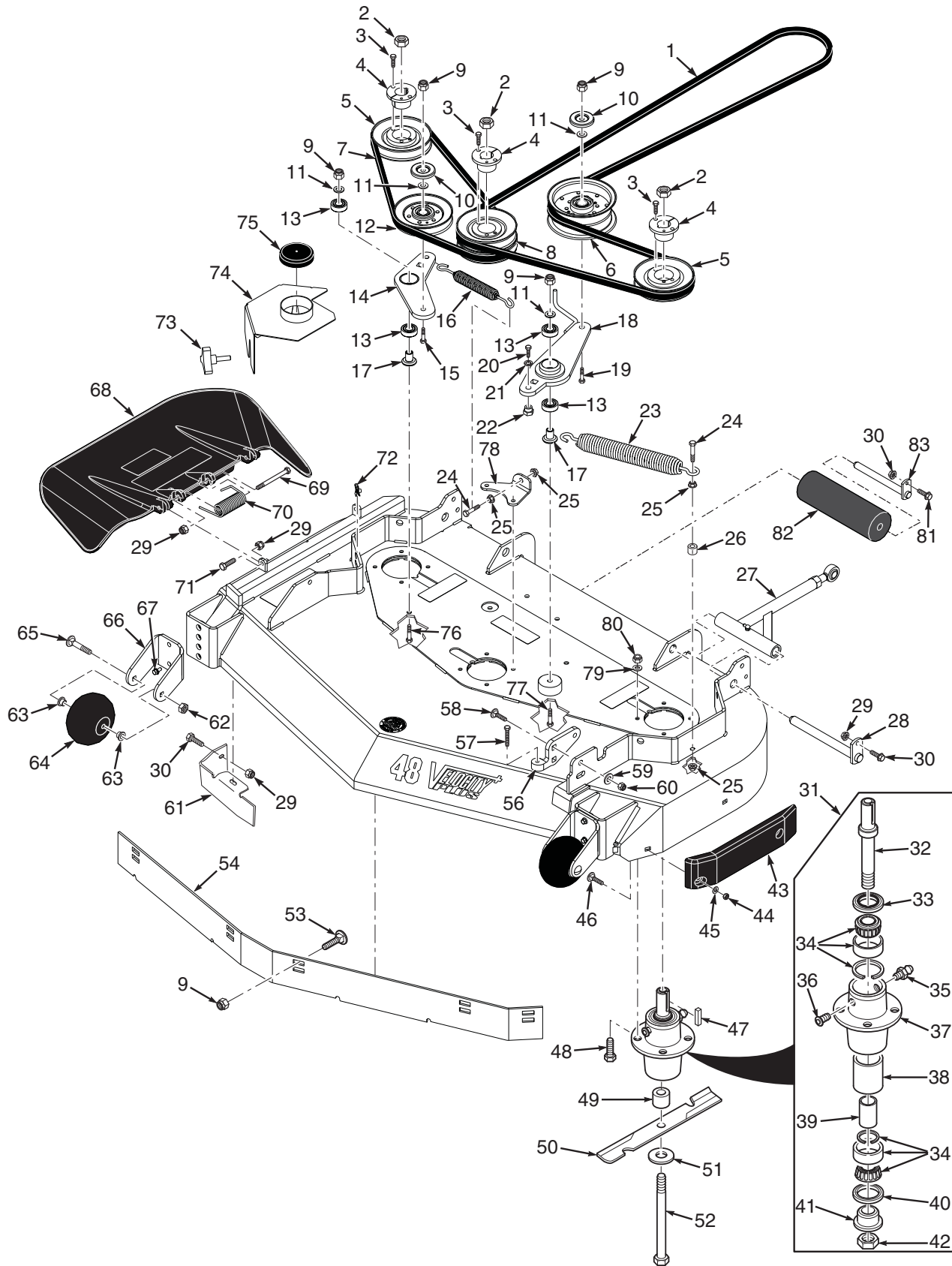

48V & 52V CUTTER DECKS

Ref. No.	Part No.	Description	48	52	Ref. No.	Part No.	Description	48	52
1	483241	Belt, Deck Drive	x		50	482877	Cutter Blade, 16.5"	x	
	483242	Belt, Deck Drive		x		482878	Cutter Blade, 18"		x
2	04020-09	Nut, 5/8-11 UNC	x	x	51	04043-06	Flatwasher, 5/8-.688 x 1.75 x .134 HD	x	x
3	04001-172	Bolt, Hex Head 1/4-20 x 1"	x	x	52	04001-41	Bolt, Hex Head 5/8-11 x 9-1/2"	x	x
4	48926	Tapered Hub, 1.125" Bore	x	x	53	04003-23	Bolt, Carriage 3/8-16 x 1"	x	x
5	483282	Pulley, 5.13" Dia.	x		54	424839	Baffle, Flange - 48V	x	
	483284	Pulley, 5.73" Dia.		x		424840	Baffle, Flange - 52V		x
6	483210	Pulley, 5" Idler	x	x	55	462501	Cutter Deck w/Decals	x	
7	483239	Belt, RH Deck Drive	x			462502	Cutter Deck w/Decals		x
	483240	Belt, RH Deck Drive		x	56	461929	Lever Assy., Deck Level	x	x
8	483283	Pulley, 5.232" Dia.	x		57	483167	Bolt, Deck Adjustment	x	x
	483285	Pulley, 5.832" Dia.		x	58	04003-40	Bolt, Carriage 7/16-14 x 1-1/4"	x	x
9	04021-09	Nut, Elastic Stop 3/8-16	x	x	59	04040-07	Flatwasher, 1/2-.531 x 1.062 x .095	x	x
10	424367	Dust Shield	x	x	60	04021-11	Nut, Elastic Stop 7/16-14	x	x
11	04043-04	Flatwasher, 3/8-.391 x .938 x .105 HD	x	x	61	424677	Baffle, Turbo	x	x
12	48181	Pulley, Idler	x	x	62	04021-05	Nut, Center Lock 3/8-16	x	x
13	48224	Bearing	x	x	63	48100-15	Bushing, .376 ID Oilite	x	x
14	461946	Idler Arm Assy. (incl. #13)	x	x	64	481632	Wheel, Anti-Scalp	x	x
15	04001-45	Bolt, Hex Head 3/8-16 x 2"	x	x	65	04003-26	Bolt, Carriage 3/8-16 x 4"	x	x
16	483247	Spring, RH Deck	x	x	66	422478	Bracket, Anti-Scalp Wheel	x	x
17	43689	Pivot, Idler	x	x	67	04017-27	Bolt, Serrated Flange 3/8-16 x 1"	x	x
18	462503	Idler Arm Assy. (incl. #13)	x	x	68	461844	Discharge Chute Assy.	x	
19	04001-54	Bolt, Hex Head 3/8-16 x 3"	x	x		461845	Discharge Chute Assy.		x
20	04001-27	Bolt, Hex Head 7/16-14 x 1"	x	x	69	04001-154	Bolt, Hex Head 5/16-18 x 4-3/4"	x	x
21	04030-05	Lockwasher, 7/16" Spring	x	x	70	483378	Spring, Discharge Chute	x	x
22	43686	Boss, Spring Anchor - LH	x	x	71	04001-12	Bolt, Hex Head 5/16-18 x 1-3/4"	x	x
23	483246	Spring, LH Deck	x	x	72	04110-03	U-Nut, 3/8-16	x	x
24	04001-136	Bolt, Hex Head 3/8-16 x 1-1/2" Grade 8	x	x	73	481625-01	Wing Nut, 3/8-16	x	x
25	04019-04	Nut, Serrated Flange 3/8-16	x	x	74	462479	Belt Cover Assy., LH	x	
26	43063	Spacer	x	x		462480	Belt Cover Assy., RH	x	
27	462463	Pusharm Assy., LH	x	x		462481	Belt Cover Assy., LH		x
	462464	Pusharm Assy., RH	x	x		462482	Belt Cover Assy., RH		x
28	451240	Rod Weldment, Pusharm	x	x	75	484368	Cap, Spindle	x	x
29	04021-10	Nut, Elastic Stop 5/16-18	x	x	76	04001-46	Bolt, Hex Head 3/8-16 x 2-1/4"	x	x
30	04001-09	Bolt, Hex Head 5/16-18 x 1"	x	x	77	04001-62	Bolt, Hex Head 3/8-16 x 3-1/4"	x	x
31	461663	Spindle Assembly	x	x	78	424376	Anchor Bracket, Spring	x	
32	43589	Shaft, Spindle	x	x		424377	Anchor Bracket, Spring		x
33	481024	Seal, Top	x	x	79	04030-03	Lockwasher, 5/16" Spring	x	x
34	481022	Bearing Assembly	x	x	80	04021-22	Nut, Elastic Stop 5/16-18 Grade 8	x	x
35	48114-04	Grease Fitting	x	x	81	04001-09	Bolt, Hex Head 5/16-18 x 1"	x	x
36	48677	Relief Fitting, Spindle	x	x	82	48038	Guide Roller	x	x
37	43644	Spindle Housing	x	x	83	45944	Shaft Weldment, Guide Roller	x	x
38	43312	Spacer, Outside	x	x					
39	43296	Spacer, Inside	x	x					
40	481025	Seal, Bottom	x	x					
41	43296	Spindle Bushing	x	x					
42	481035	Nut, Special 1-1/16 - 18	x	x					
43	483176	Wear Pad	x	x					
44	04021-04	Nut, Center Lock 5/16-18	x	x					
45	04040-04	Flatwasher, 5/16-.344 x .688 x .065	x	x					
46	04003-12	Bolt, Carriage 5/16-18 x 3/4"	x	x					
47	04063-08	Key, 1/4 x 1/4 x 2"	x	x					
48	04001-176	Bolt, Hex Head 5/16-18 x 1-3/4" Grade 8	x	x					
49	43590	Spacer, Spindle Bottom	x	x					

CUTTER DECK CONTROLS

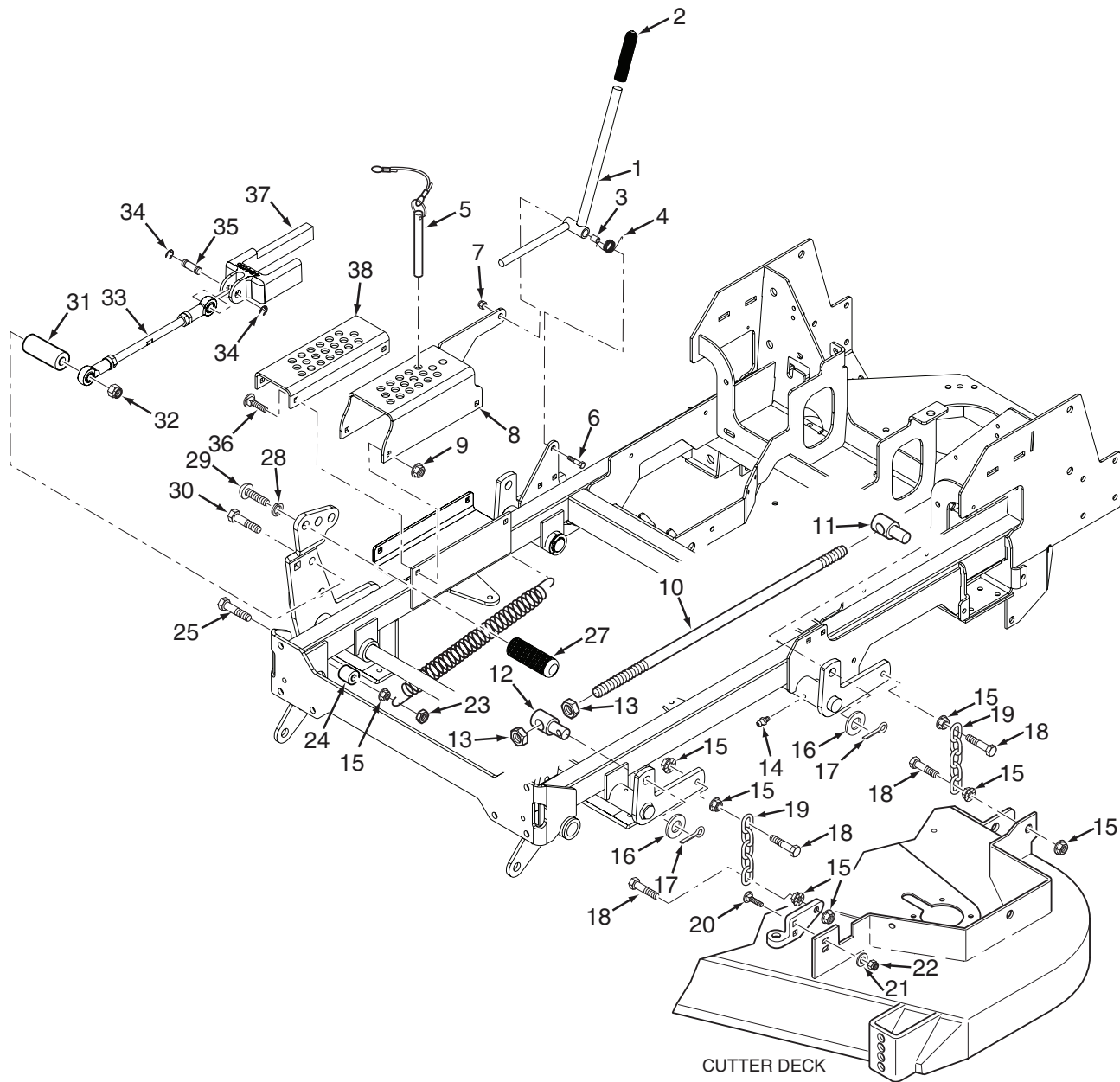

CUTTER DECK CONTROLS

Ref. No.	Part No.	Description
1	462451	Deck Latch Assembly (incl. #2)
2	481477	Grip, Deck Latch
3	43874	Spacer, Deck Latch
4	484191	Spring, Torsion - Lever Return
5	483345	Pin Assembly, w/Lanyard
6	04001-54	Bolt, Hex Head 3/8-16 x 3"
7	04021-09	Nut, Elastic Stop 3/8-16
8	425737	Adjustment Bracket, Cutting Height
9	*04019-03	Nut, Serrated Flange 5/16-18 *(See Page 53 for Serial Number Range)
10	04004-45	Stud, 1/2-13 x 20"
11	43678	Swivel Joint, LH
12	43679	Swivel Joint, RH
13	04020-07	Nut, 1/2-13
14	48114-04	Grease Fitting, 1/4-28 Self Tap
15	04019-04	Nut, Serrated Flange 3/8-16
16	04040-09	Flatwasher, 5/8-.656 x 1.312 x .095
17	04061-07	Cotter Pin, 3/16 x 1"
18	04001-20	Bolt, Hex Head 3/8-16 x 1-1/2"
19	48540	Chain
20	04003-40	Bolt, Carriage 7/16-14 x 1-1/4"
21	04040-07	Flatwasher, 1/2-.531 x 1.062 x .095
22	04021-11	Nut, Elastic Stop 7/16-11
23	04021-05	Nut, Center Lock 3/8-16
24	43572	Spacer
25	04001-32	Bolt, Hex Head 3/8-16 x 1-1/4"
26	483177	Spring, Helper
27	424504	Foot Pedal, Height Adjustment
28	04030-07	Lockwasher, 5/8" Spring
29	04105-01	Capscrew, 5/8-11 x 1-1/2"
30	04001-87	Bolt, Hex Head 1/2-13 x 4"
31	43873	Spacer, Deck Lift Pedal
32	04021-07	Nut, Elastic Stop 1/2-13
33	482534	Linkage Assembly, Deck Lift
	482624	Rod, Deck Lift
	04020-28	Jam Nut, 1/2-20 LH Thread
	481766	Rod End, 1/2-20 LH Female
	04020-27	Jam Nut, 1/2-20 RH Thread
	481765	Rod End, 1/2-20 RH Female
34	04050-10	Retaining Ring, 1/2" Ext. "E"
35	43487	Pin, Deck Lift
36	*04003-04	Bolt, Carriage 5/16-18 x 1" *(See Page 53 for Serial Number Range)
	*04001-09	Bolt, Hex Head 5/16-18 x 1"
	*04030-03	Lockwasher, 5/16" Spring *(See Page 55 for Serial Number Range)
37	484115	Slide, Height Adjust
38	*425361	Adjustment Bracket, Lower Cut Height *(See Page 53 for Serial Number Range)
	*452408	Adjustment Bracket, Lower Cut Height *(See Page 55 for Serial Number Range)

SHEET METAL COMPONENTS

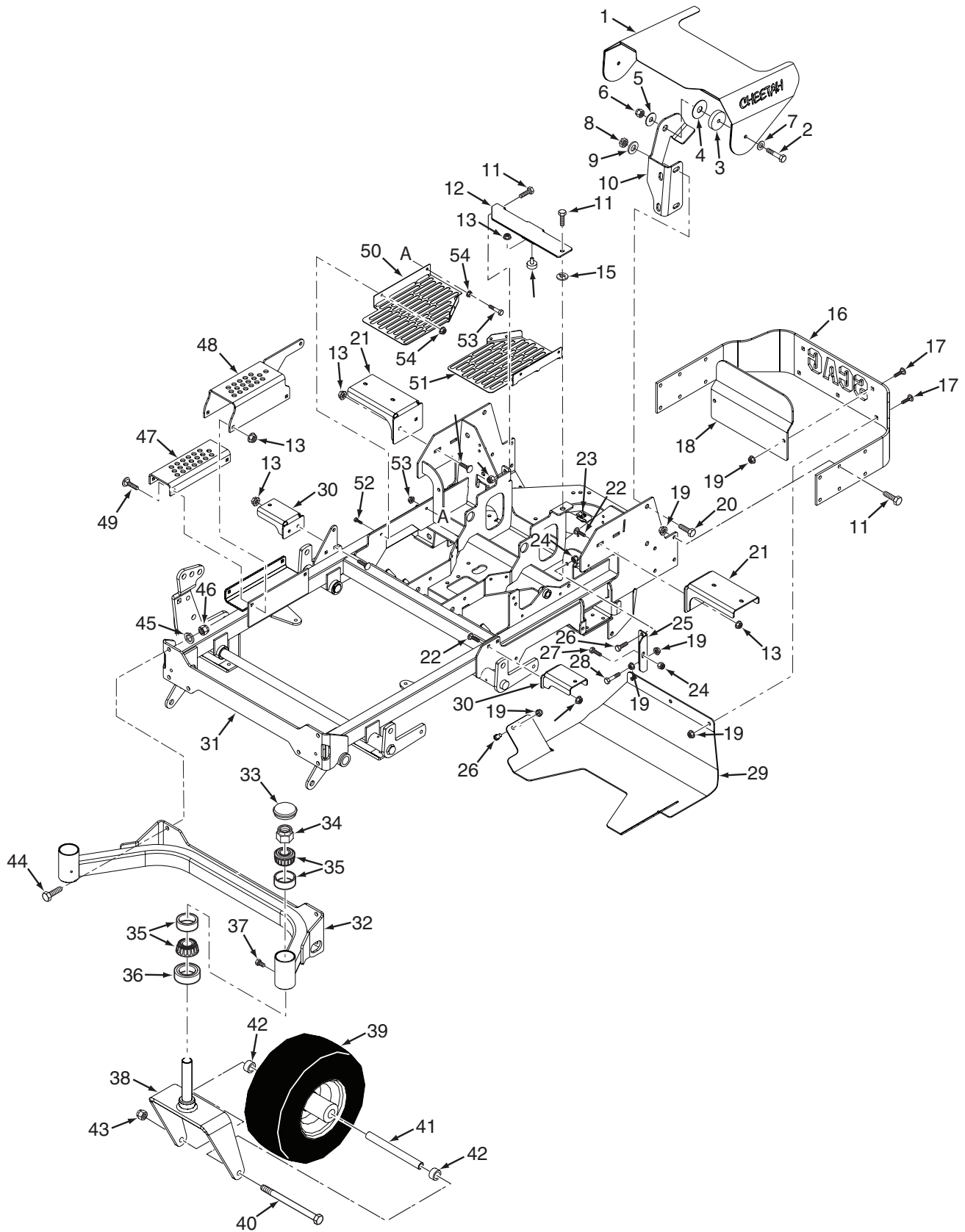

SHEET METAL COMPONENTS

Ref. No.	Part No.	Description
1	462504	Hood Assembly
	462556	Hood Assembly, EFI
2	04001-21	Bolt, Hex Head 3/8-16 x 1-3/4"
3	43740	Spacer, Hood
4	483471	Disk, Anti-Friction
5	04041-11	Flatwasher, 3/8-.406 x 1.50 x 7 Ga.
6	04021-09	Nut, Elastic Stop 3/8-16
7	04041-07	Flatwasher, 3/8-.391 x .938 x .105
8	04021-09	Nut, Center Lock 1/2-13
9	04040-13	Flatwasher, 1/2-.562 x 1.375 x .109
10	425961	ROPS Mount, LH
	425962	ROPS Mount, RH
11	04001-19	Bolt, Hex Head 3/8-16 x 1"
12	425422	Cover, Battery Box
13	04019-03	Nut, Serrated Flange 5/16-18
14	481581	Bumper, Rubber
15	04024-02	Nut, Push-On 3/8 Thread
16	425725	Bumper, Rear
17	04003-23	Bolt, Carriage 3/8-16 x 1"
18	425926	Guard, Engine
19	04019-04	Nut, Serrated Flange 3/8-16
20	04001-70	Bolt, Hex Head 1/2-13 x 1-1/4"
21	425350	Mounting Bracket, Fuel Tank Rear
22	04003-12	Bolt, Carriage 5/16-18 x 3/4"
23	04110-03	U-Nut, 3/8-16
24	04021-09	Nut, Elastic Stop 3/8-16
25	425907	Anchor Bracket, Pum Spring
26	04001-19	Bolt, Hex Head 3/8-16 x 1"
27	04001-32	Bolt, Hex Head 3/8-16 x 1-1/4"
28	04001-136	Bolt, Hex Head 3/8-16 x 1-1/2" Grade 8
29	425724	Plate, Skid
30	425862	Mounting Bracket, Fuel Tank Front
31	*462493	Mainframe Assembly, w/Decals *(See Page 53 for Serial Number Range)
	*462562	Mainframe Assembly, w/Decals *(See Page 55 for Serial Number Range)
32	452284	Caster Weldment
33	484195	Cap, Grease
34	04021-20	Nut, Elastic Stop 1"-14
35	481657	Bearing w/Race
36	481025	Seal, 2" O.D. x 1.625 Bore
37	482028-01	Plug, 1/4-28
38	451658	Yoke Weldment
39	9278	Caster Wheel Assembly
	482621	Bearing
	48114-10	Grease Fitting
40	04001-167	Bolt, Hex Head 1/2-13 x 9-1/2"
41	43583	Sleeve, Caster Wheel
42	43584	Spacer, Caster Wheel
43	04021-07	Nut, Elastic Stop 1/2-13
44	04001-28	Bolt, Hex Head 7/16-14 x 1-1/4"
45	04030-05	Lockwasher, 7/16" Spring

Ref. No.	Part No.	Description
46	04021-11	Nut, Elastic Stop 7/16-14
47	*425361	Adjustment Bracket, Lower Cut Height *(See Page 53 for Serial Number Range)
	452408	Adjustment Bracket, Lower Cut Height *(See Page 55 for Serial Number Range)
48	425737	Adjustment Bracket, Cutting Height
49	*04003-04	Bolt, Carriage 5/16-18 x 1" *(See Page 53 for Serial Number Range)
	*04001-09	Bolt, Hex Head 5/16-18 x 1"
	*04030-03	Lockwasher, 5/16" Spring *(See Page 55 for Serial Number Range)
50	425747	Fan Cover, RH
51	425746	Fan Cover, LH
52	04001-01	Bolt, Hex Head 1/4-20 x 3/4"
53	04001-59	Bolt, Hex Head 1/4-20 x 1-1/4"
54	04019-02	Nut, Serrated Flange 1/4-20

SCZ ROLL-OVER PROTECTION SYSTEM

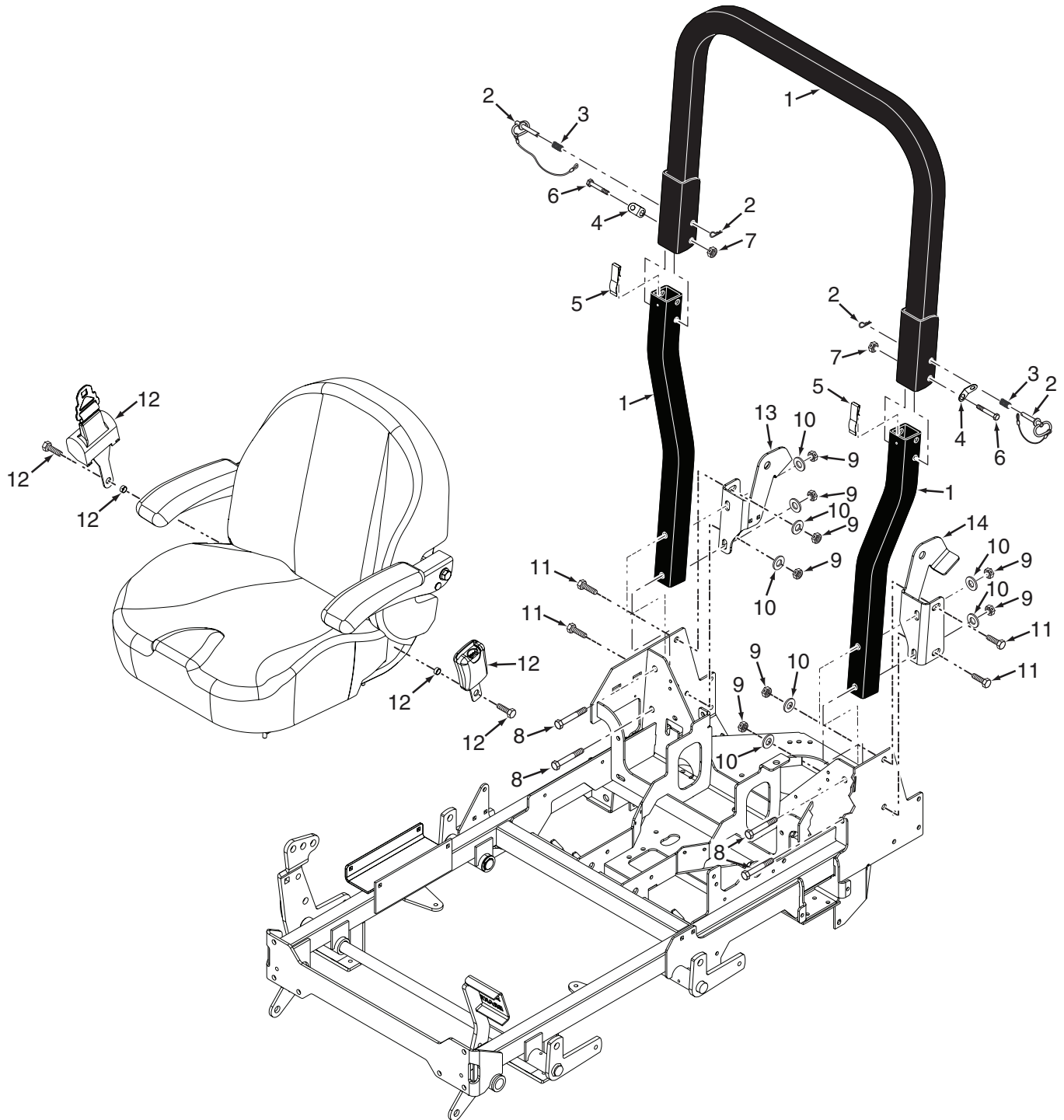

SCZ ROLL-OVER PROTECTION SYSTEM

Ref. No.	Part No.	Description
1	462414	ROPS Assembly, Foldable
2	484168	Pin Assembly (incl. #3)
3	484170	Spring, ROPS
4	484169	Clip, ROPS
5	484167	Spring, ROPS Anti-Rattle
6	04001-90	Bolt, Hex Head 1/2-13 x 3-1/4"
7	04021-07	Nut, Elastic Stop 1/2-13
8	04001-145	Bolt, Hex Head 1/2-13 x 3-1/2"
9	04021-19	Nut, Center Lock 1/2-13
10	04040-13	Flatwasher, 1/2-.562 x 1.375 x .109
11	04001-70	Bolt, Hex Head 1/2-13 x 1-1/4"
12	484527	Seat Belt Kit
13	425962	ROPS Mount, RH
14	425961	ROPS Mount, LH

SCZ SEAT ASSEMBLY

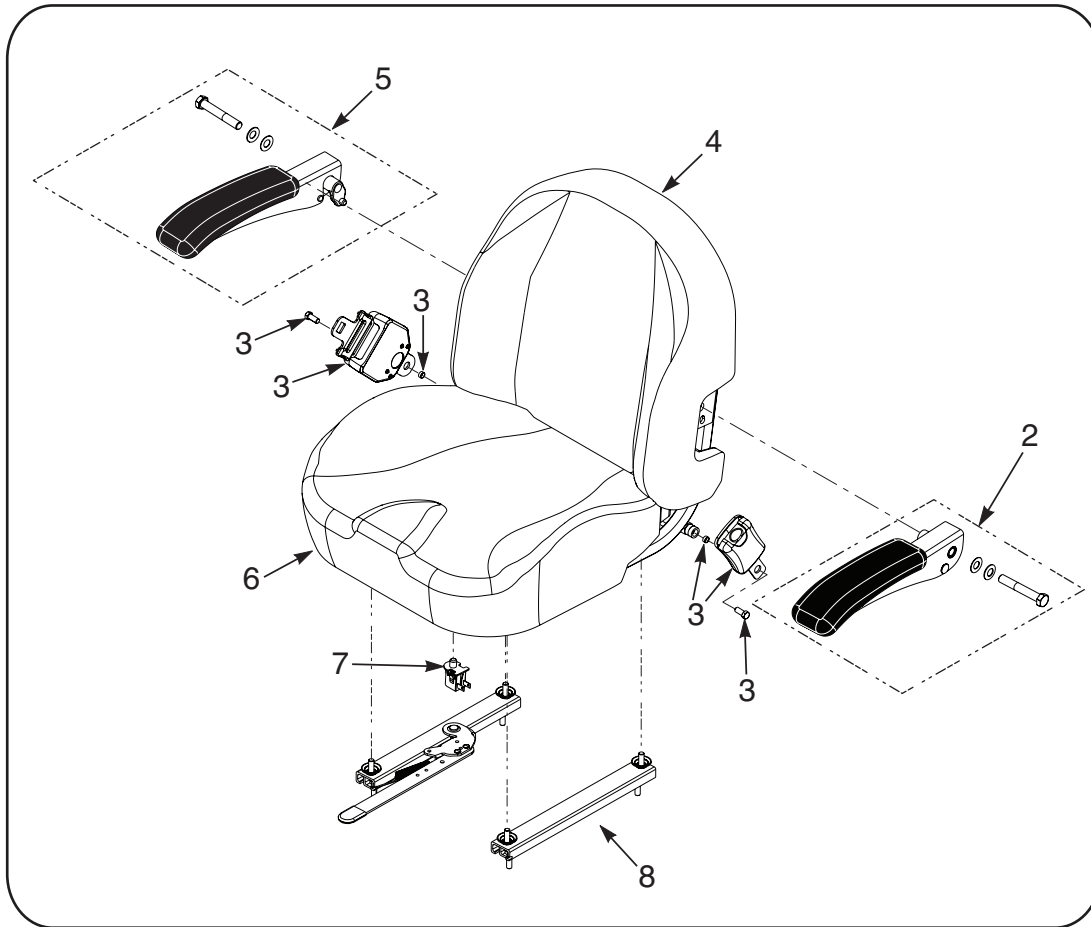

Ref. No.	Part No.	Description
1	484588	Seat Assembly
2	484754	Armrest Kit, LH
3	484527	Seat Belt Kit
4	484528	Back Cover
5	484755	Armrest Kit, RH
6	484529	Cushion Cover
7	481638	Seat Switch
8	484608	Track Kit, 6"

NOTES

SCZ SUSPENSION SYSTEM (SEE SERIAL NUMBER RANGE ON THE NEXT PAGE)

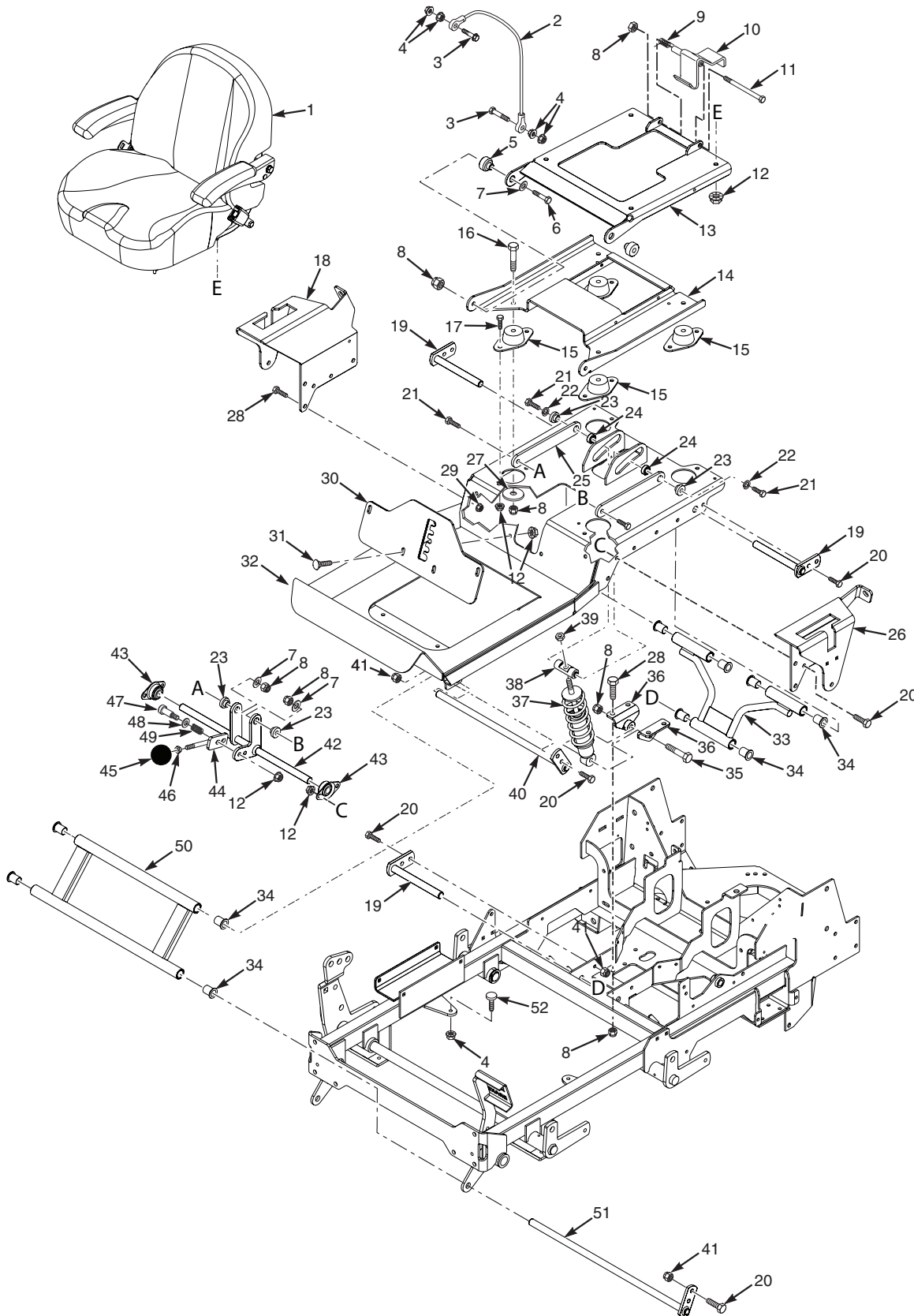

SCZ SUSPENSION SYSTEM (SEE SERIAL NUMBER RANGE BELOW)

Ref. No.	Part No.	Description
1	484588	Seat Assembly
2	483559	Cable, Seat Stop
3	04001-59	Bolt, Hex Head 1/4-20 x 1-1/4"
4	04019-02	Nut, Serrated Flange 1/4-20
5	43606	Sleeve, Seat Base Mount
6	04001-45	Bolt, Hex Head 3/8-16 x 2"
7	04041-07	Flatwasher, 3/8-.391 x .938 x .105
8	04021-09	Nut, Elastic Stop 3/8-16
9	483371	Spring, Seat Latch
10	452143	Latch Weldment, Seat
11	04001-100	Bolt, Hex Head 3/8-16 x 6"
12	04019-03	Nut, Serrated Flange 5/16-18
13	452147	Seat Plate Weldment
14	462262	Seat Mounting Plate Weldment w/Decal
15	484148	Isolator, Seat
16	04001-46	Bolt, Hex Head 3/8-16 x 2-1/4"
17	04001-08	Bolt, Hex Head 5/16-18 x 3/4"
18	462264	Bracket Weld., Control Lever RH w/Decal
19	452152	Shaft Weldment, Rear Op. Platform Pivot
20	04001-09	Bolt, Hex Head 5/16-18 x 1"
21	04001-20	Bolt, Hex Head 3/8-16 x 1-1/2"
22	04030-04	Lockwasher, 3/8" Spring
23	43086	Bushing
24	484035	Bearing
25	425257	Link, Suspension Seat Tensioner
26	462263	Bracket Weld., Control Lever LH w/Decal

Ref. No.	Part No.	Description
27	04041-38	Flatwasher, 3/8-.406 x 2.25 x .188
28	04001-19	Bolt, Hex Head 3/8-16 x 1"
29	04019-04	Nut, Serrated Flange 3/816
30	462267	Bracket, Suspension Adjustment w/Decal
31	04003-04	Bolt, Carriage 5/16-18 x 1"
32	462497	Seat Mounting Base Weldment w/Decal
33	462212	Suspension Pivot Assembly, Rear
34	483453-14	Bearing
35	04001-22	Bolt, Hex Head 3/8-16 x 2-3/4"
36	452154	Mount Weldment, Shock
37	484032	Shock Absorber, Suspension
38	484150	Mount, Suspension Shock
39	04021-18	Nut, Elastic Stop 3/8-24 Grade 8
40	452151	Pin Weldment, Op Platform Upper Pivot
41	04021-10	Nut, Elastic Stop 5/16-18
42	452107	Pivot Weldment, Suspension Tensioner
43	48796	Bearing, Self Align 5/8" ID
44	452106	Adjustment Lever, Suspension
45	484010	Knob
46	04020-12	Nut, Jam 3/8-16
47	04009-11	Bolt, Shoulder 3/8 x 1"
	04009-14	Bolt, Shoulder 3/8 x 3/8"
48	04050-05	Flatwasher, 3/8-.406 x .812 x .065
49	483601	Spring
50	462400	Suspension Pivot Assembly, Front
51	452150	Pin Weldment, Op Platform Lower Pivot
52	484201	Bumper, Rubber

Illustration for models produced in the following serial number range:

SCZ48V-691FX	with a serial number of	H6700001 to H6700999
SCZ48V-25CV	with a serial number of	H6800001 to H6800999
SCZ48V-28BS	with a serial number of	H6900001 to H6900999
SCZ52V-730FX	with a serial number of	H7000001 to H7000999
SCZ52V-27CV	with a serial number of	H7100001 to H7100999
SCZ52V-28BS	with a serial number of	H7200001 to H7200999
Always use the entire serial number listed on the serial number tag when referring to this product.		

SCZ SUSPENSION SYSTEM (SEE SERIAL NUMBER RANGE ON THE NEXT PAGE)

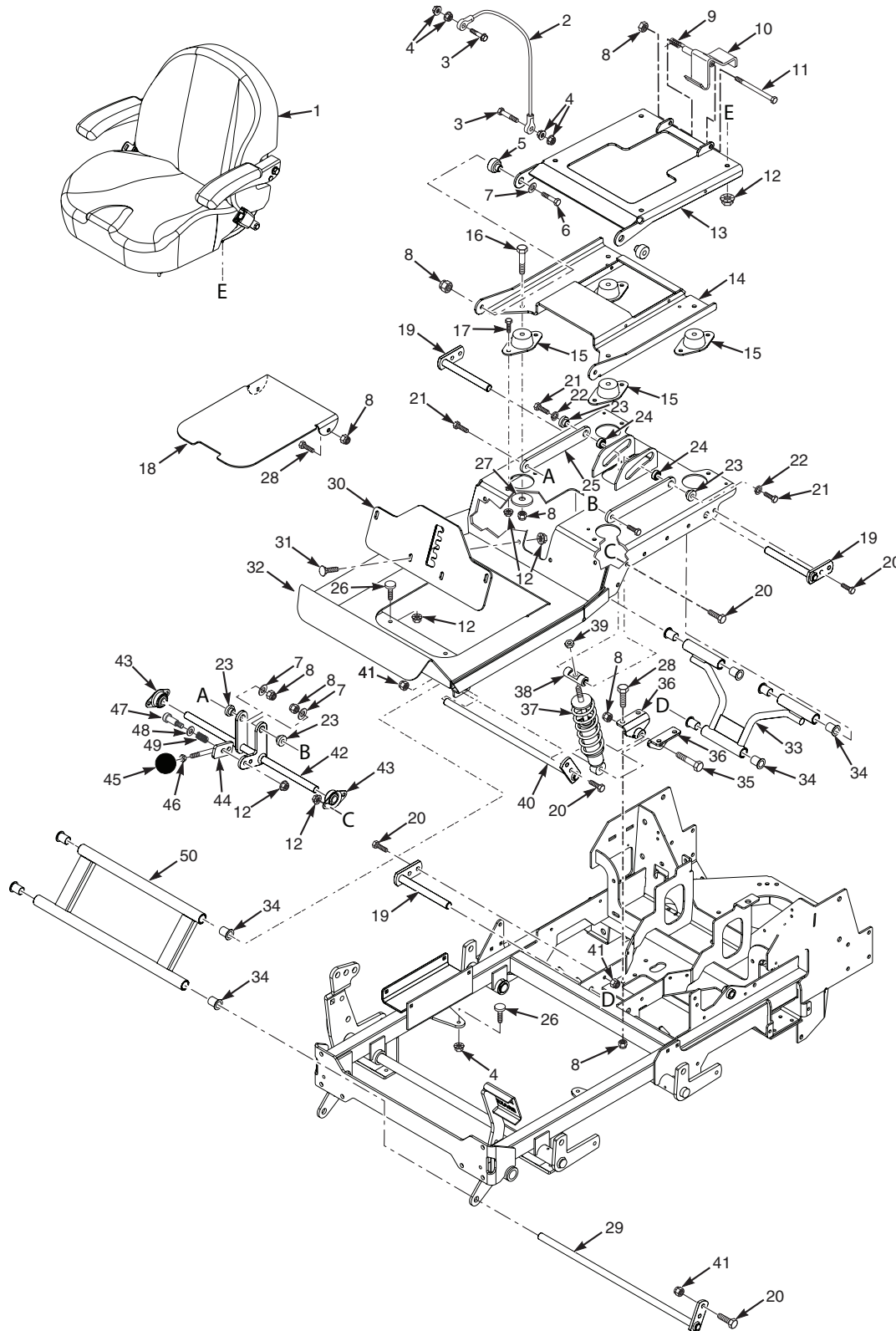

SCZ SUSPENSION SYSTEM (SEE SERIAL NUMBER RANGE BELOW)

Ref. No.	Part No.	Description
1	484588	Seat Assembly
2	483559	Cable, Seat Stop
3	04001-59	Bolt, Hex Head 1/4-20 x 1-1/4"
4	04019-02	Nut, Serrated Flange 1/4-20
5	43606	Sleeve, Seat Base Mount
6	04001-45	Bolt, Hex Head 3/8-16 x 2"
7	04041-07	Flatwasher, 3/8-.391 x .938 x .105
8	04021-09	Nut, Elastic Stop 3/8-16
9	483371	Spring, Seat Latch
10	452143	Latch Weldment, Seat
11	04001-100	Bolt, Hex Head 3/8-16 x 6"
12	04019-03	Nut, Serrated Flange 5/16-18
13	452147	Seat Plate Weldment
14	462262	Seat Mounting Plate Weldment w/Decal
15	484148	Isolator, Seat
16	04001-46	Bolt, Hex Head 3/8-16 x 2-1/4"
17	04001-08	Bolt, Hex Head 5/16-18 x 3/4"
18	425566	Cover, Foot Plate
19	452152	Shaft Weldment, Rear Op. Platform Pivot
20	04001-09	Bolt, Hex Head 5/16-18 x 1"
21	04001-20	Bolt, Hex Head 3/8-16 x 1-1/2"
22	04030-04	Lockwasher, 3/8" Spring
23	43086	Bushing
24	484035	Bearing
25	425257	Link, Suspension Seat Tensioner
26	484201	Bumper, Rubber

Ref. No.	Part No.	Description
27	04041-38	Flatwasher, 3/8-.406 x 2.25 x .188
28	04001-19	Bolt, Hex Head 3/8-16 x 1"
29	452150	Pin Weldment, Op Platform Lower Pivot
30	462267	Bracket, Suspension Adjustment w/Decal
31	04003-04	Bolt, Carriage 5/16-18 x 1"
32	462497	Seat Mounting Base Weldment w/Decal
33	462212	Suspension Pivot Assembly, Rear
34	483453-14	Bearing
35	04001-22	Bolt, Hex Head 3/8-16 x 2-3/4"
36	452154	Mount Weldment, Shock
37	484032	Shock Absorber, Suspension
38	484150	Mount, Suspension Shock
39	04021-18	Nut, Elastic Stop 3/8-24 Grade 8
40	452151	Pin Weldment, Op Platform Upper Pivot
41	04021-10	Nut, Elastic Stop 5/16-18
42	452107	Pivot Weldment, Suspension Tensioner
43	48796	Bearing, Self Align 5/8" ID
44	452106	Adjustment Lever, Suspension
45	484010	Knob
46	04020-12	Nut, Jam 3/8-16
47	04009-11	Bolt, Shoulder 3/8 x 1"
	04009-14	Bolt, Shoulder 3/8 x 3/8"
48	04050-05	Flatwasher, 3/8-.406 x .812 x .065
49	483601	Spring
50	462400	Suspension Pivot Assembly, Front

Illustration for models produced in the following serial number range:		
SCZ48V-691FX	with a serial number of	H6701000 to H6799999
SCZ48V-25CV	with a serial number of	H6801000 to H6899999
SCZ48V-28BS	with a serial number of	H6901000 to H6999999
SCZ52V-730FX	with a serial number of	H7001000 to H7099999
SCZ52V-27CV	with a serial number of	H7101000 to H7199999
SCZ52V-28BS	with a serial number of	H7201000 to H7299999
Always use the entire serial number listed on the serial number tag when referring to this product.		

SCZ STEERING & FOOT PLATFORM COMPONENTS (SEE SERIAL NUMBER RANGE ON THE NEXT PAGE)

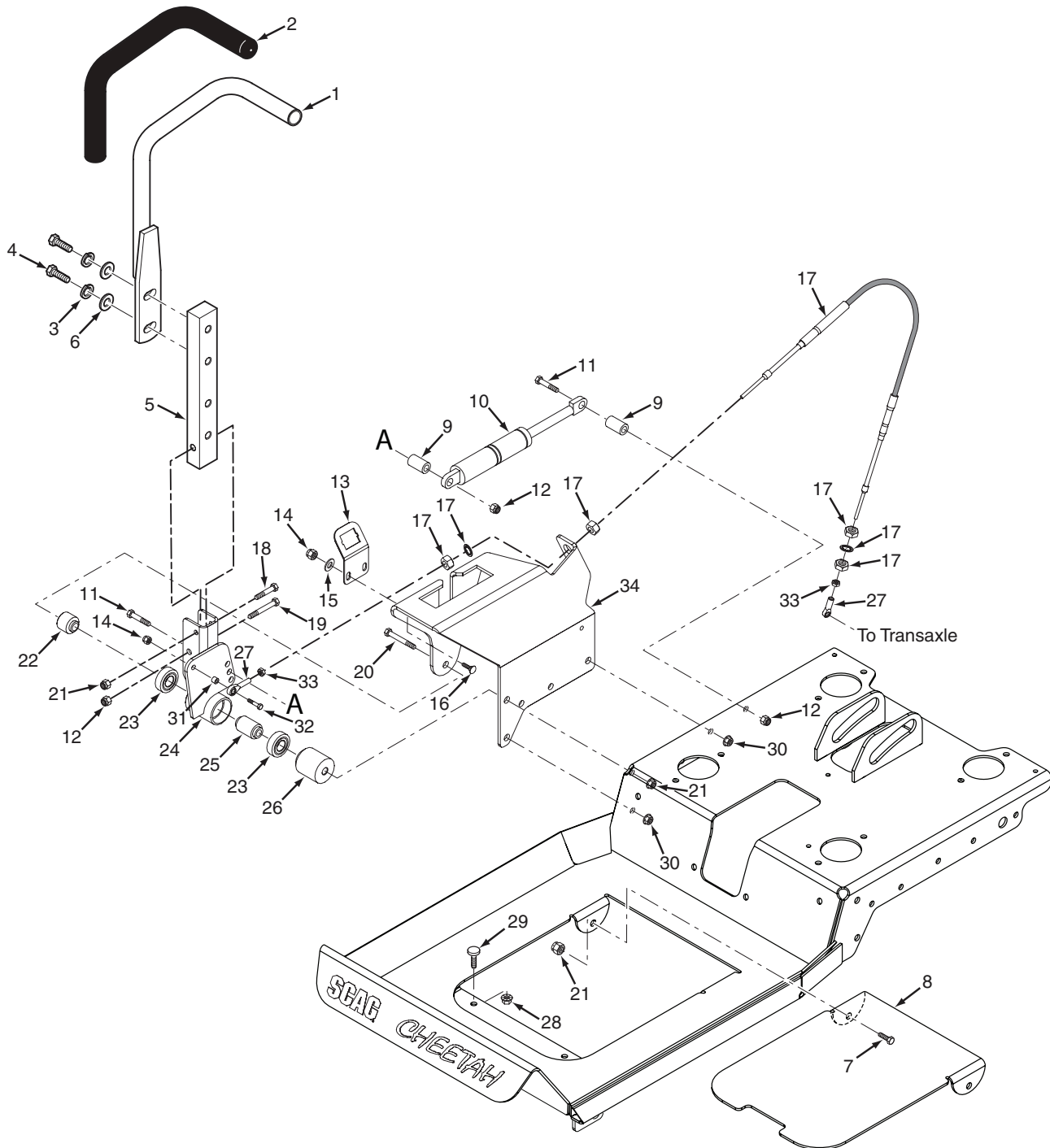

SCZ STEERING & FOOT PLATFORM COMPONENTS (SEE SERIAL NUMBER RANGE BELOW)

Ref. No.	Part No.	Description
1	462401	Handle Bar w/Grip
2	484376	Grip, Control Handle
3	04030-04	Lockwasher, 3/8" Spring
4	04001-32	Bolt, Hex Head 3/8-16 x 1-1/4"
5	422372	Bar, Control Lever
6	04041-07	Flatwasher, 3/8-.391 x .938 x .105
7	04001-19	Bolt, Hex Head 3/8-16 x 1"
8	425566	Cover, Foot Plate
9	43833	Spacer
10	484193	Damper
11	04001-17	Bolt, Hex Head 5/16-18 x 2"
12	04021-10	Nut, Elastic Stop 5/16-18
13	425389	Bracket, Operator Presence Switch
14	04021-08	Nut, Elastic Stop 1/4-20
15	04040-14	Flatwasher, 1/4-.312 x .750 x .065
16	04003-02	Bolt, Carriage 1/4-20 x 3/4"
17	484485	Control Cable, Hydro
18	04001-45	Bolt, Hex Head 3/8-16 x 2"
19	04001-17	Bolt, Hex Head 5/16-18 x 2"
20	04001-100	Bolt, Hex Head 3/8-16 x 6"
21	04021-09	Nut, Elastic Stop 3/8-16
22	43607	Spacer, Controls
23	48224	Bearing
24	452110	Pivot Weldment, Control Arm LH
	452111	Pivot Weldment, Control Arm RH
25	43600	Spacer, Bearing
26	43823	Spacer, Controls
27	484040	Rod End, 1/4-28 RH Thread
28	04019-03	Nut, Serrated Flange 5/16-18
29	484201	Bumper, Rubber
30	04019-04	Nut, Serrated Flange 3/8-16
31	43827	Spacer
32	04001-59	Bolt, Hex Head 1/4-20 x 1-1/4"
33	04020-22	Nut, Jam 1/4-28 UNF
34	462264	Bracket Weldment, Control Lever RH w/Decal
	462263	Bracket Weldment, Control Lever LH w/Decal

Illustration for models produced in the following serial number range:		
SCZ48V-691FX	with a serial number of	H6700001 to H6700048
SCZ48V-25CV	with a serial number of	H6800001 to H6800999
SCZ48V-28BS	with a serial number of	H6900001 to H6900999
SCZ52V-730FX	with a serial number of	H7000001 to H7000999
SCZ52V-27CV	with a serial number of	H7100001 to H7100999
SCZ52V-28BS	with a serial number of	H7200001 to H7200999
Always use the entire serial number listed on the serial number tag when referring to this product.		

SCZ STEERING COMPONENTS (SEE SERIAL NUMBER RANGE ON THE NEXT PAGE)

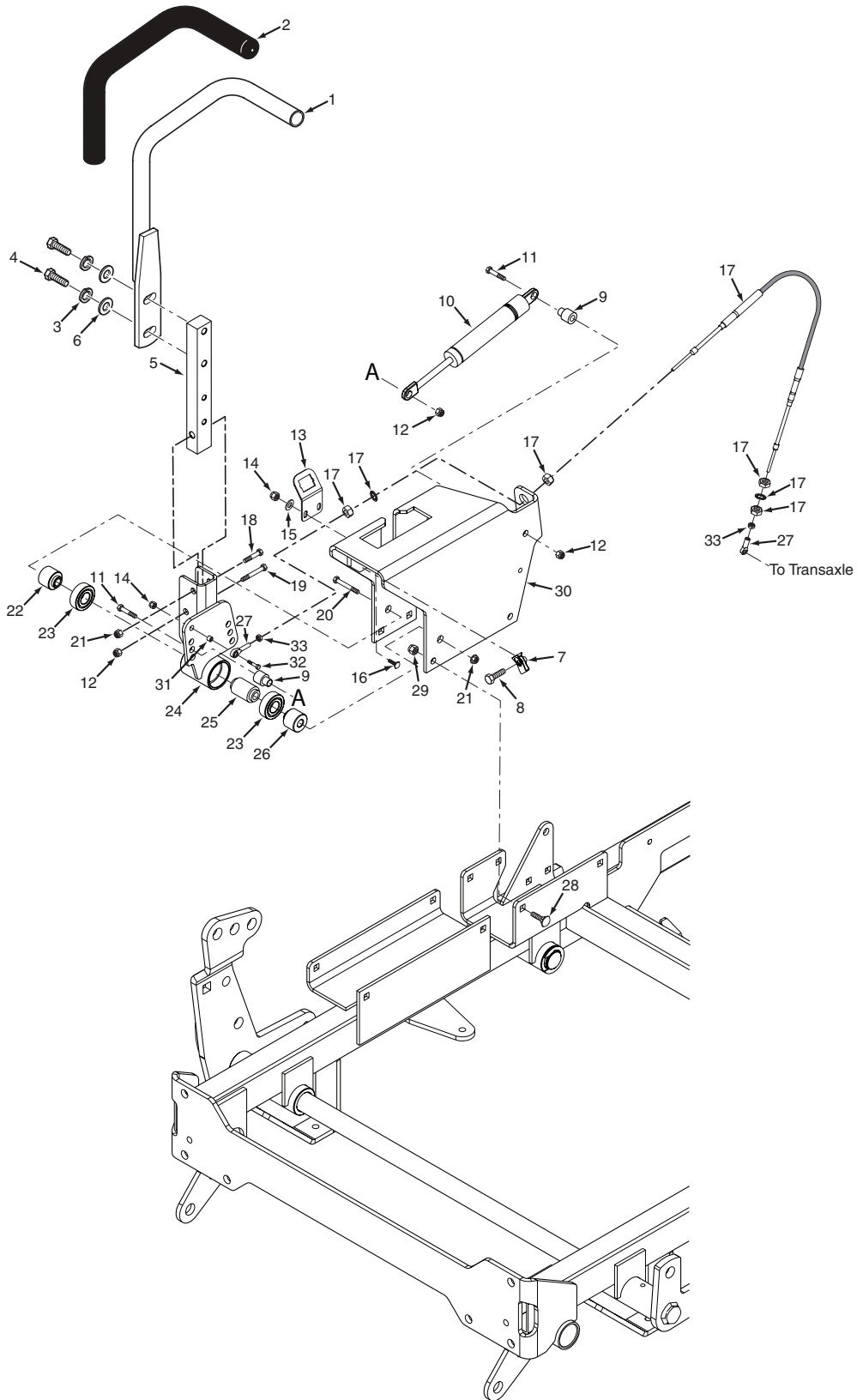

Section 8

SCZ STEERING COMPONENTS (SEE SERIAL NUMBER RANGE BELOW)

Ref. No.	Part No.	Description
1	462401	Handle Bar w/Grip
2	484376	Grip, Control Handle
3	04030-04	Lockwasher, 3/8" Spring
4	04001-32	Bolt, Hex Head 3/8-16 x 1-1/4"
5	422372	Bar, Control Lever
6	04041-07	Flatwasher, 3/8-.391 x .938 x .105
7	04110-03	U-Nut, 3/8-16
8	04107-04	Bolt, Hex Head 3/8-16 x 2" Special
9	43602	Spacer
10	484193	Damper
11	04001-11	Bolt, Hex Head 5/16-18 x 1-1/2"
12	04021-10	Nut, Elastic Stop 5/16-18
13	425905	Bracket, Operator Presence Switch
14	04021-08	Nut, Elastic Stop 1/4-20
15	04040-14	Flatwasher, 1/4-.312 x .750 x .065
16	04003-02	Bolt, Carriage 1/4-20 x 3/4"
17	484485	Control Cable, Hydro
18	04001-45	Bolt, Hex Head 3/8-16 x 2"
19	04001-17	Bolt, Hex Head 5/16-18 x 2"
20	04001-23	Bolt, Hex Head 3/8-16 x 4-1/2"
21	04021-09	Nut, Elastic Stop 3/8-16
22	43607	Spacer, Controls
23	48224	Bearing
24	452406	Pivot Weldment, Control Arm LH
	452407	Pivot Weldment, Control Arm RH
25	43600	Spacer, Bearing
26	43823	Spacer, Controls
27	484040	Rod End, 1/4-28 RH Thread
28	04003-04	Bolt, Carriage 5/16-18 x 1"
29	04019-03	Nut, Serrated Flange 5/16-18
30	462561	Bracket Weldment, Control Lever RH w/Decal
	462560	Bracket Weldment, Control Lever LH w/Decal
31	43827	Spacer
32	04001-59	Bolt, Hex Head 1/4-20 x 1-1/4"
33	04020-22	Nut, Jam 1/4-28 UNF

Illustration for models produced in the following serial number range:		
SCZ48V-691FX	with a serial number of	H6700049 to H6799999
SCZ48V-25CV	with a serial number of	H6801000 to H6899999
SCZ48V-28BS	with a serial number of	H6901000 to H6999999
SCZ52V-730FX	with a serial number of	H7001000 to H7099999
SCZ52V-27CV	with a serial number of	H7101000 to H7199999
SCZ52V-28BS	with a serial number of	H7201000 to H7299999
Always use the entire serial number listed on the serial number tag when referring to this product.		

SCZ DRIVE SYSTEM COMPONENTS

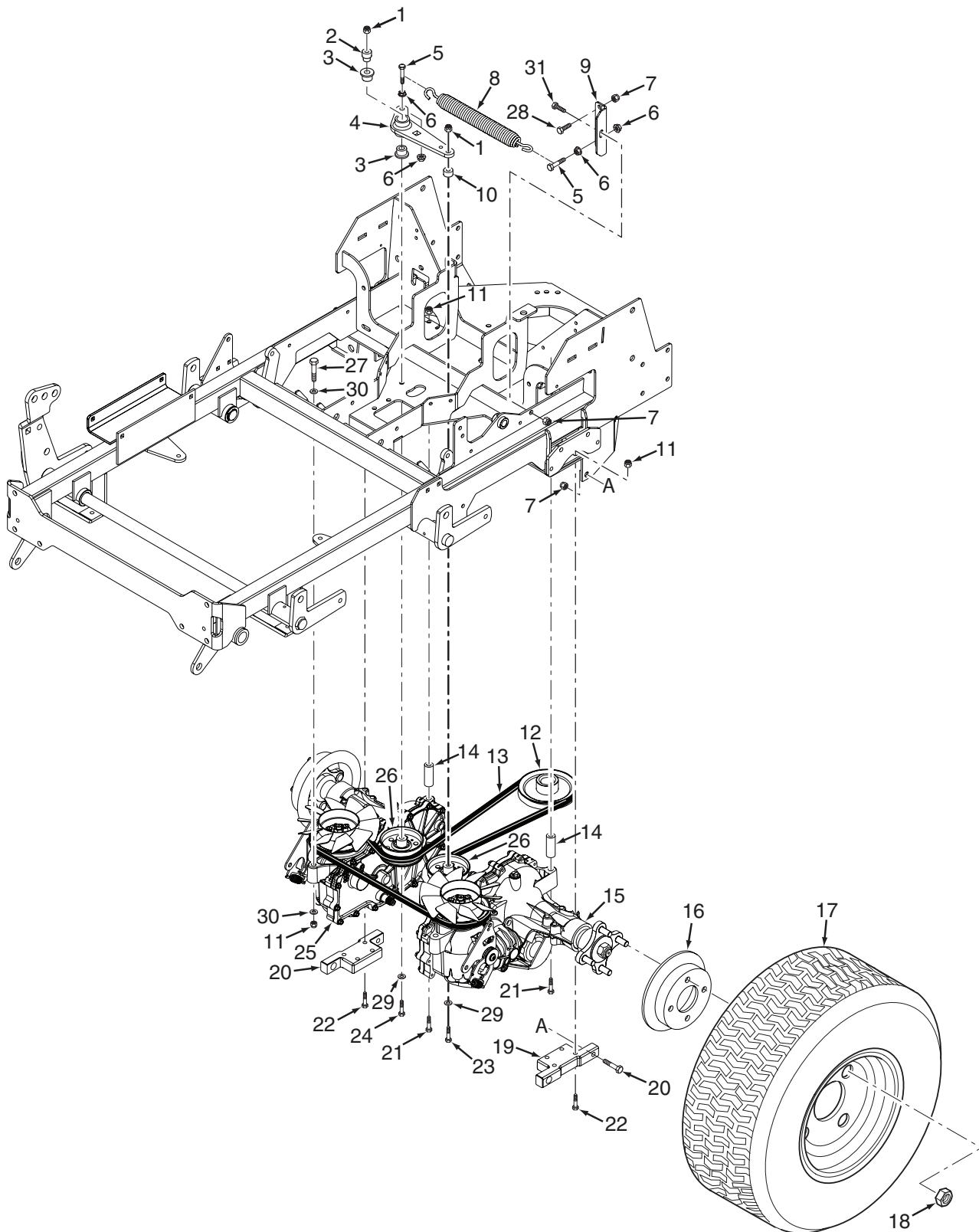

SCZ DRIVE SYSTEM COMPONENTS

Ref. No.	Part No.	Description
1	04021-09	Nut, Elastic Stop 3/8-16
2	43715	Shaft, Pivot Idler Arm
3	483453-04	Bearing
4	462492	Idler Arm Assembly (incl. #3)
5	04001-136	Bolt, Hex Head 3/8-16 x 1-1/2" Grade 8
6	04019-04	Nut, Serrated Flange 3/8-16
7	04021-09	Nut, Elastic Stop 3/8-16
8	484560	Spring, Pump Drive
9	425907	Anchor Bracket, Pump Spring
10	43572	Spacer
11	04021-10	Nut, Elastic Stop 5/16-18
12	484373	Pulley, 5" Dia. - 1.125" Bore
13	484372	Belt, Pump Drive
14	43857	Spacer, Axle
15	484454	Transaxle, LH
16	43853	Spacer, Axle
17	484558	Wheel Assembly, 23 x 9.5-12 (48)
	481659	Rim (48)
	484466	Tire, 23 x 9.5-12
	484465	Wheel Assembly, 23 x 9.5-12 (52)
	482414	Rim (52)
18	04028-02	Wheel Nut, 1/2-20
19	484480	Mount, Pusharm
20	04001-142	Bolt, Hex Head 5/8-11 x 2-1/2"
21	04001-154	Bolt, Hex Head 5/16-18 x 4-3/4"
22	04001-76	Bolt, Hex Head 5/16-18 x 4"
23	04001-62	Bolt, Hex Head 3/8-16 x 3-1/4"
24	04001-152	Bolt, Hex Head 3/8-16 x 4-1/4"
25	484455	Transaxle, RH
26	483638	Pulley, 3-1/2" Idler
27	04001-39	Bolt, Hex Head 5/16-18 x 2-1/4"
28	04001-19	Bolt, Hex Head 3/8-16 x 1"
29	04043-04	Flatwasher, 3/8-.391 x .938 x .105 HD
30	04040-15	Flatwasher, 5/16-.375 x .875 x .083
31	04001-32	Bolt, Hex Head 3/8-16 x 1-1/4"

SCZ BRAKE COMPONENTS

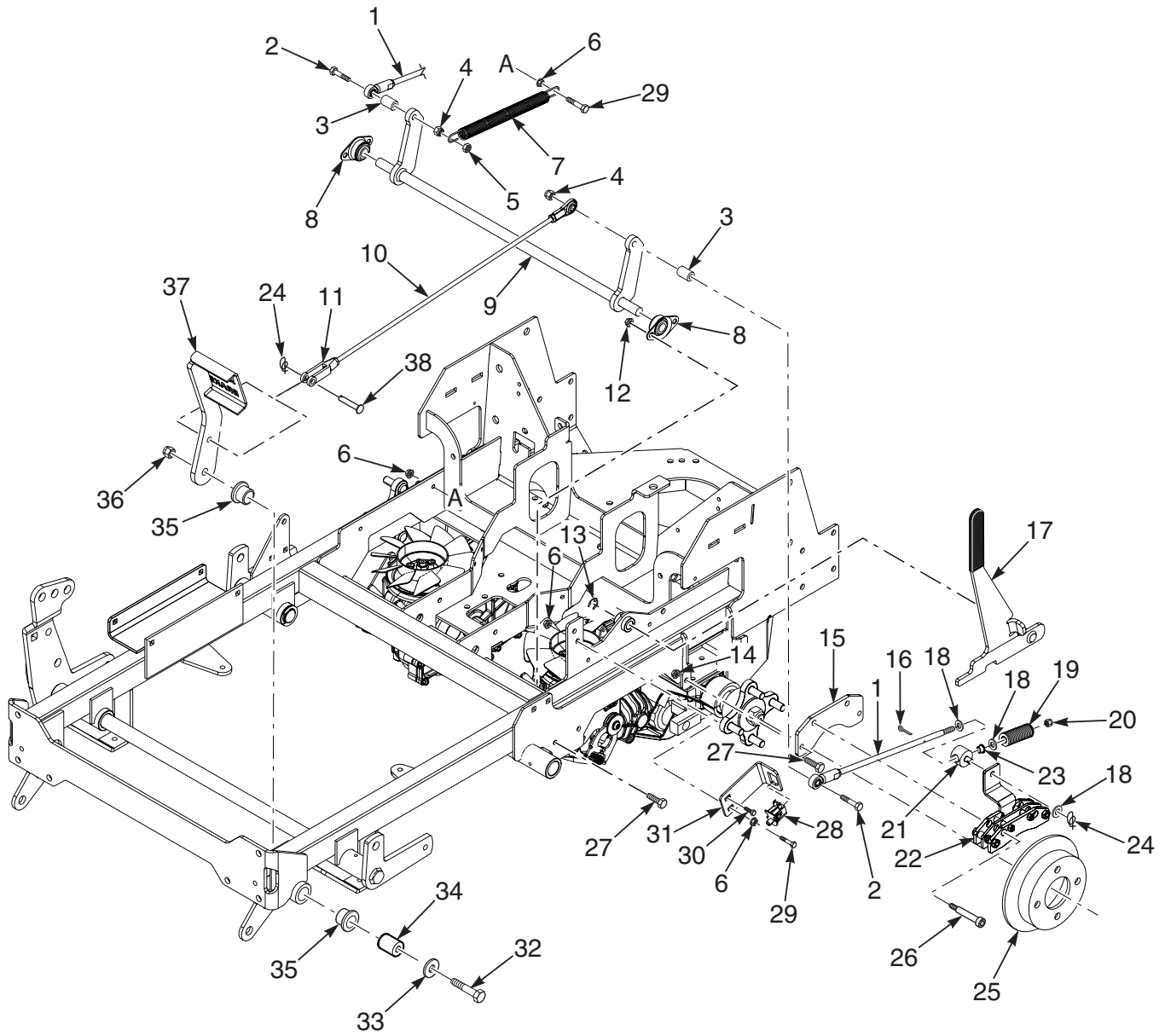

SCZ BRAKE COMPONENTS

Ref. No.	Part No.	Description
1	462465	Brake Link Assembly (incl. #16, 18, 19, 20, 21)
2	04001-54	Bolt, Hex Head 3/8-16 x 3"
3	43572	Spacer
4	04021-09	Nut, Elastic Stop 3/8-16
5	04021-05	Nut, Center Lock 3/8-16
6	04019-02	Nut, Serrated Flange 1/4-20
7	484575	Spring, Brake Return
8	48796	Bearing, Self Align - 5/8" I.D.
9	452342	Brake Bellcrank Weldment
10	492001	Brake Rod Assembly
	483340	Rod End, 3/8-24 LH
	04020-26	Nut, 3/8-24 UNF LH Jam
11	48343-04	Clevis
	04020-25	Nut, 3/8-24 UNF Jam
12	04021-10	Nut, Elastic Stop 5/16-18
13	04050-01	Retaining Ring, .625 Ext "E"
14	04019-03	Nut, Serrated Flange 5/16-18
15	425706	Mounting Bracket, Brake
16	04061-02	Cotter Pin, 3/32 x 3/4"
17	462466	Lever w/Grip, Parking Brake
	482102	Grip, Brake Lever
18	04040-05	Flatwasher, 3/8-.406 x .812 x .065
19	484535	Spring, Brake
20	04021-18	Nut, Elastic Stop 3/8-24
21	462452	Swivel Assembly, Brake
22	483701	Brake Caliper
23	483453-23	Bearing
24	04069-01	Pin, Rue Cotter - 3/8" Dia.
25	43853	Brake Hub
26	04009-10	Bolt, 1/2 x 2-3/4" Shoulder
27	04001-59	Bolt, Hex Head 5/16-18 x 3/4"
28	481638	Switch
29	04001-59	Bolt, Hex Head 1/4-20 x 1-1/4"
30	04003-07	Bolt, Carriage 1/4-20 x 1/2"
31	425858	Switch Mounting Bracket, Brake
32	04001-194	Bolt, Hex Head 1/2-13 x 4-1/4"
33	04040-13	Flatwasher, 1/2-.562 x 1.375 x .109
34	43872	Sleeve, Brake Pivot
35	483453-03	Bearing
36	04021-07	Nut, Elastic Stop 1/2-13
37	452327	Brake Pedal Weldment
38	04064-02	Clevis Pin, 3/8 x 1.06"

SCZ HYDRAULIC SYSTEM

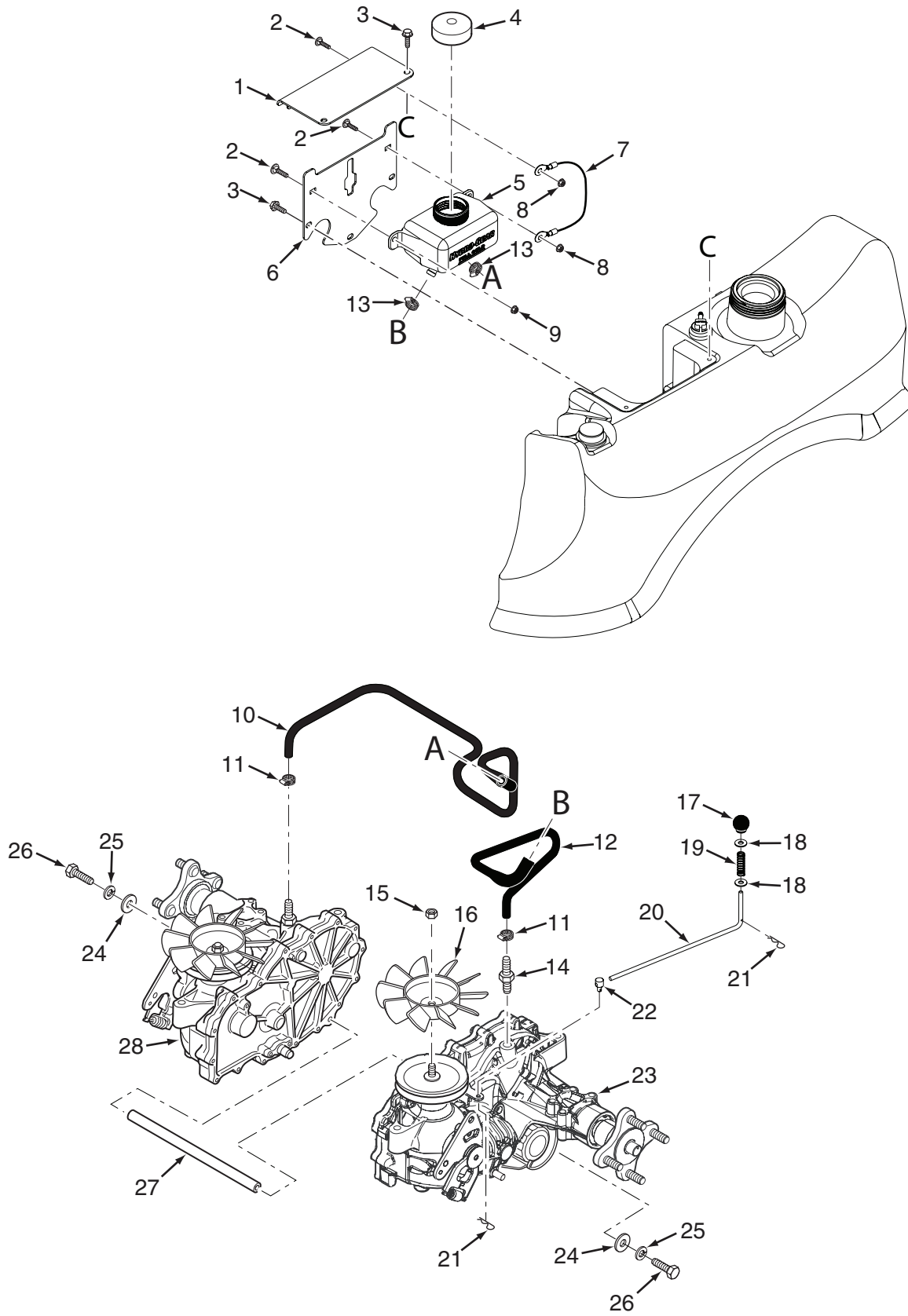

SCZ HYDRAULIC SYSTEM

Ref. No.	Part No.	Description
1	425861	Cover, Oil Reservoir
2	04003-02	Bolt, Carriage 1/4-20 x 3/4"
3	04017-04	Bolt, Serrated Flange 1/4-20 x 1/2"
4	483514	Cap, Oil Reservoir
5	484517	Oil Reservoir Assembly (incl. #4)
6	425860	Mounting Bracket, Oil Reservoir
7	484196	Lanyard, Oil Reservoir Cover
8	04117-03	Nut, Flanged Elastic Stop 1/4-20
9	04021-08	Nut, Elastic Stop 1/4-20
10	484607	Hose, RH Transaxle
11	48136-13	Clamp, .69 Max Dia.
12	484537	Hose, LH Transaxle
13	48136-05	Clamp, .87 Max Dia.
14	482800-04	Fitting, Transmission
15	HG44133	Fan Nut
16		Fan (order through Hydro-Gear)
17	484573	Knob, Dump Lever
18	04040-14	Flatwasher, 1/4-.312 x .750 x .065
19	482070	Spring
20	44186	Linkage, Dump Valve
21	04062-02	Hair Pin Cotter
22	43876	Joint, Swivel
23	484454	Transaxle, LH
24	04041-07	Flatwasher, 3/8-.391 x .938 x .105
25	04030-04	Lockwasher, 3/8" Spring
26	04001-46	Bolt, Hex Head 3/8-16 x 2-1/4"
27	43864	Spacer, Axles
28	484455	Transaxle, RH

SCZ FUEL SYSTEM

Ref. No.	Part No.	Description
1	484286	Fuel Cap, Tethered
	484297	Fuel Cap, Tethered (California Only)
2	484279-01	Tube, Fuel Tank Insert - 4"
3	484323	Fuel Gauge Assembly (incl. #4)
4	484242	Seal, Fuel Gauge
5	462445	Fuel Tank Assembly, RH (incl. #3, 6, 7, 8, 9)
6	484553	Fuel Tube Assembly
7	482571	Bushing, .56 Viton
8	484333	Remote Vent
9	484285	Grommet, Viton
10	48059-15	Clamp, Vapor Recovery Hose
11	484345	Hose, 3/16" (order by inch)
12	48059-02	Clamp, Fuel Hose 7/32
13	484347	Hose, Vapor Recovery (order by inch)
14	484343-01	Mender, 1/4 x 3/16
15	484287	Carbon Canister, 400cc
	484366	Dust Filter, Carbon Canister
16	484552	Fuel Tube Assembly, LH
17	462444	Fuel Tank Assembly, LH (incl. # 3, 7, 8, 9, 16)
18	48059-01	Clamp, Fuel Hose 1/4" I.D.
19	425886	Mounting Bracket, Fuel Valve
20	482212	Valve, Fuel Shut Off
21	48935-02	Tee, 3/16 x 3/16 x 3/16 Union, Hose Barb
22	483617	Hose, Non-Perm Fuel 1/4" I.D.
23	**	Fuel Filter

** Available through the individual engine manufacturer.

SCZ ENGINE & ATTACHING PARTS

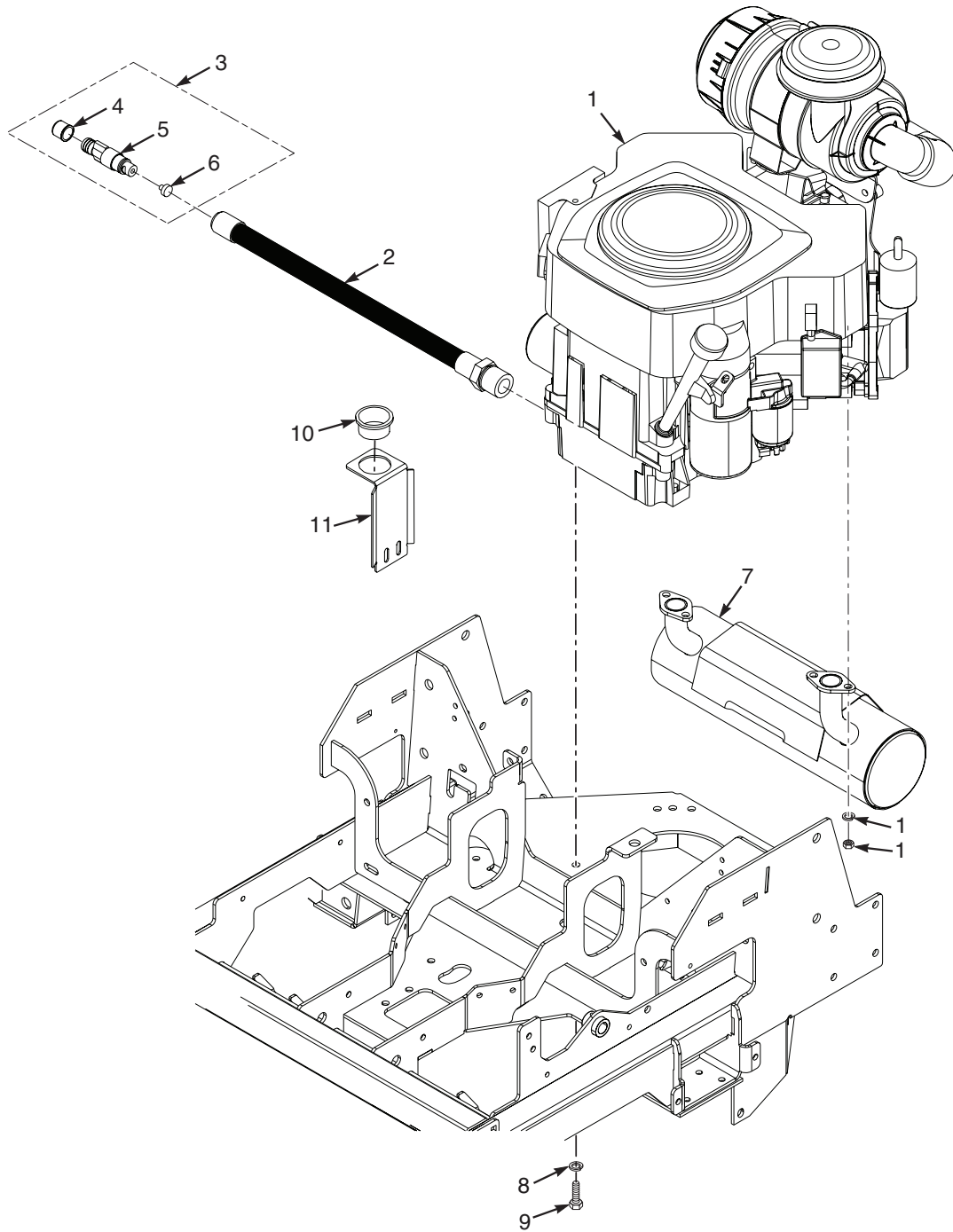

SCZ ENGINE & ATTACHING PARTS

Ref. No.	Part No.	Description
1	**484414	Engine, Kawasaki FX691V
	**484226	Engine, Kohler CV730
	**484415	Engine, Kawasaki FX730V
	**484227	Engine, Kohler CV740
	**484690	Engine, Kohler ECV740
	**484561	Engine, Briggs & Stratton 44L977
2	484581	Hose Assembly, Engine Oil Drain - Kawasaki FS/FX (incl. #3, 4, 5, 6)
	484628	Hose, Oil Drain - Briggs & Stratton ELS (incl. #3, 4, 5, 6)
	484610	Hose, Oil Drain - Kohler CV (incl. #3, 4, 5, 6)
3	484593	Valve Assembly, Oil Drain
4	484585	Cap
5	48603-12	O-Ring
6	484586	Seal
7	484751	Muffler, Kawasaki FS/FX
	484567	Muffler, Briggs & Stratton
	484568	Muffler, Kohler CV
	484650	Muffler, Kohler ECV (EFI)
8	04030-04	Lockwasher, 3/8" Spring (Kawasaki)
9	04001-32	Bolt, Hex Head 3/8-16 x 1-1/4" (Kawasaki)
	04011-07	Bolt, Hex Head 3/8-16 x 1-1/4" Self Tap (Briggs and Kohler)
	04001-11	Bolt, Hex Head 5/16-18 x 1-1/2" (Right Front Engine Mounting, Briggs and Kohler Only)
	04019-03	Nut, Serrated Flange 5/16-18 (Right Front Engine Mounting, Briggs and Kohler Only)
10	484617	Bushing, Thick Panel Snap
11	426040	Bracket, Oil Drain Hose

** Available through the individual engine manufacturer.

ZT-3400 TRANSAXLE ASSEMBLY

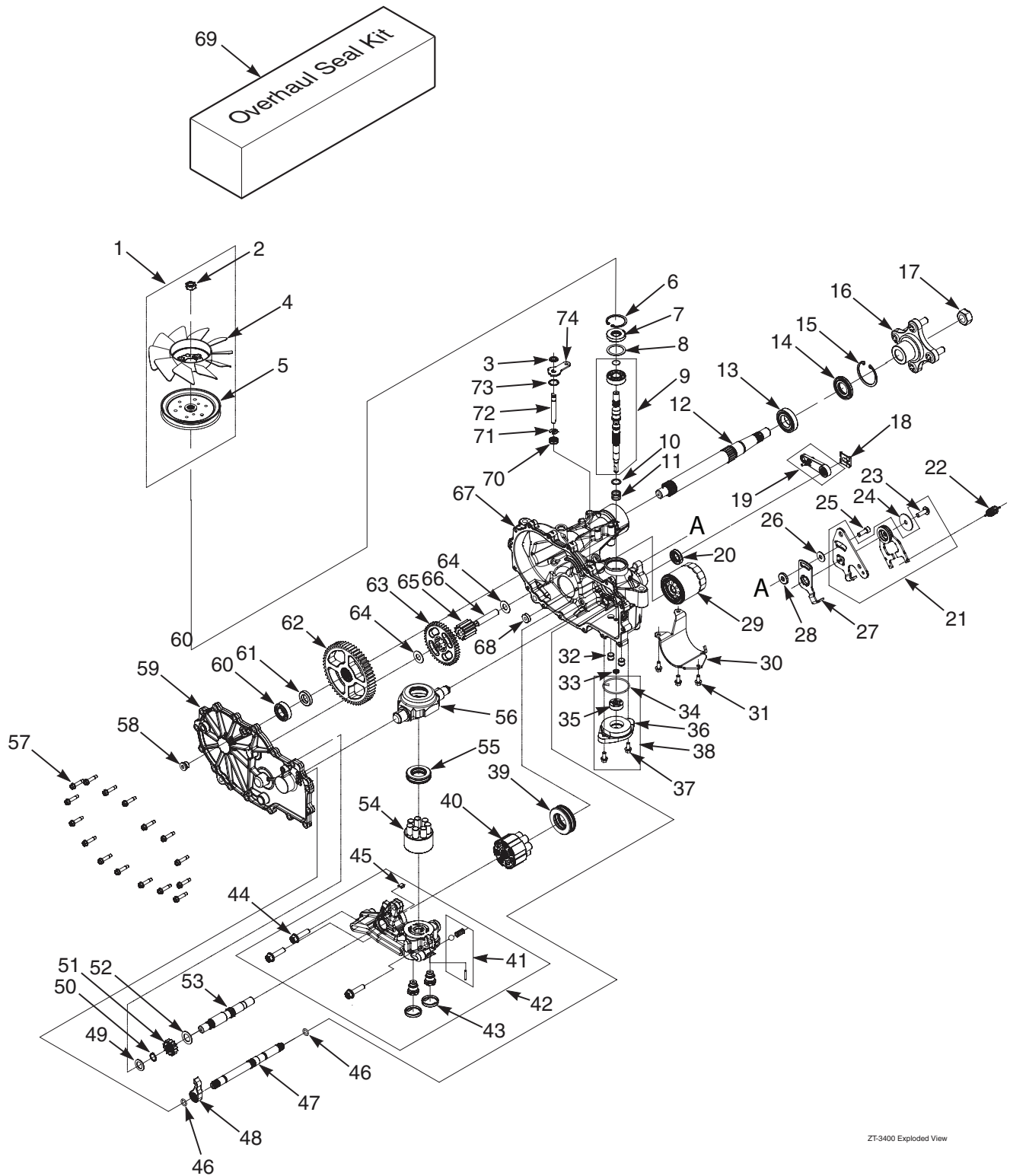

ZT-3400 Exploded View

ZT-3400 TRANSAXLE ASSEMBLY

Ref. No.	Part No.	Description	Ref. No.	Part No.	Description
1	HG71907	Kit, Fan & Pulley	40	HG71579	Assembly, Cylinder Block
2	HG44133	Nut, Elastic Stop 1/2-20	41	HG71436	Kit, Charge Relief
3	HG51523	Washer, OD Slotted .53 x 1.63 x .06	42	HG71972	Kit, Center Section (Right Side)
4	HG52747	Fan, 7" (10 Blade)		HG71973	Kit, Center Section (Left Side)
5	HG53435	Pulley"	43	HG52162	Seal, Plug 1.250 x .250
6	HG53029	Ring, Retaining	44	HG52137	HFHCS, 3/8-16 X 1-1/2" Patch
7	HG51161	Seal, Lip 17 x 40 x 7	45	HG51448	Plate, By-Pass
8	HG50951	Washer, 1.23 x 1.56 x .04	46	HG51804	O-Ring, -111 x .103 x 424
9	HG71978	Kit, Input Shaft	47	HG42640	Shaft, Brake
10	HG2003017	Washer, Flat .59 x .79 x .04	48	HG52776	Pawl, Brake
11	HG2003014	Spring, Block	49	HG44371	Washer, .63 x 1 x .05
12	HG53528	Shaft, Axle	50	HG44145	Ring, Retaining .625
13	HG50771	Bearing, Ball 25.4 x 52 x 15	51	HG52342	Gear, 13T Steel
14	HG50772	Seal, Lip 1 x 2.049 x .375	52	HG51069	Washer, .72 x 1.16 x .04
15	HG50859	Ring, Retaining 2.06 Internal	53	HG52150	Shaft, Motor
16	HG71405	Hub, 4-Bolt	54	HG71971	Assembly, Block 7 Piston
17	HG50863	Nut, Hex Lock 3/4-16	55	HG53502	Bearing, Thrust
18	HG52027	Clip, Retaining	56	HG51048	Trunnion, Swashplate
19	HG52639	Handle, Brake Actuating	57	HG53246	HFHCS, 1/4-20 x 1-1/8"
20	HG51140	Seal, Lip 12 x 32 x 7	58	HG9005110	Plug, 9/16-18
21	HG71595	Kit, RTN Bi-Directional (Left Side)		-5600	
	HG71598	Kit, RTN Bi-Directional (Right Side)	59	HG71990	Kit, Cover (Right Side)
22	HG51605	Spring, RTN		HG71992	Kit, Cover (Left Side)
23	HG51812	Bolt, Hex Head Cap Screw 5/16-24 x 1" Patch	60	HG44121	Bearing, Ball .75 x 40 x 12
24	HG51950	Washer, .343 x 1.5 x .062	61	HG53336	Spacer, .750 x 1.320 x .257
25	HG51616	Bolt, Hex Head Cap Screw 5/16-24 x 1" Patch	62	HG43327	Gear, 54T
26	HG44130	Washer, .34 x .88 x .06	63	HG52110	Gear, 45T
27	HG51945	Arm, Neutral (Right Side)	64	HG50132	Washer, .5 X 1 X .03
	HG51946	Arm, Neutral (Left Side)	65	HG52341	Gear, 14T Steel
28	HG52527	Spacer, .320 x 1.005 x .179	66	HG51083	Jackshaft Pin
29	HG52114	Filter, Oil	67	HG72025	Kit, Housing Main (Right Side)
30	HG52257	Guard, Filter (Right Side)		HG72026	Kit, Housing Main (Left Side)
	HG52247	Guard, Filter (Left Side)	68	HG51100	Magnet, Ring
31	HG53464	Screw, Hex Flange 1/4-20 x .625	69	HG71976	Seal Kit
32	HG52157	Tibe, Connecting	70	HG51626	Seal, Lip .375 x .75 x .25
33	HG53456	Seal, Lip 8 x 12 x 3-VC	71	HG51628	Ring, Retaining .375 External
34	HG52250	O-Ring, -137 x .103 x 2.050	72	HG52136	Rod, By-Pass
35	HG50273	Gerotor Assembly (1.9 cc)	73	HG51677	Ring, Retaining .750 Internal
36	HG53468	Cover, Charge Pump	74	HG51629	Arm, By-Pass
37	HG53464	Screw, Hex Flange 1/4-20 x .625	75	HG51630	Ring, Retaining .375 External
38	HG71977	Kit, Charge Pump			
39	HG51462	Bearing, Thrust			

SCZ ELECTRICAL SYSTEM (SEE SERIAL NUMBER RANGE ON THE NEXT PAGE)

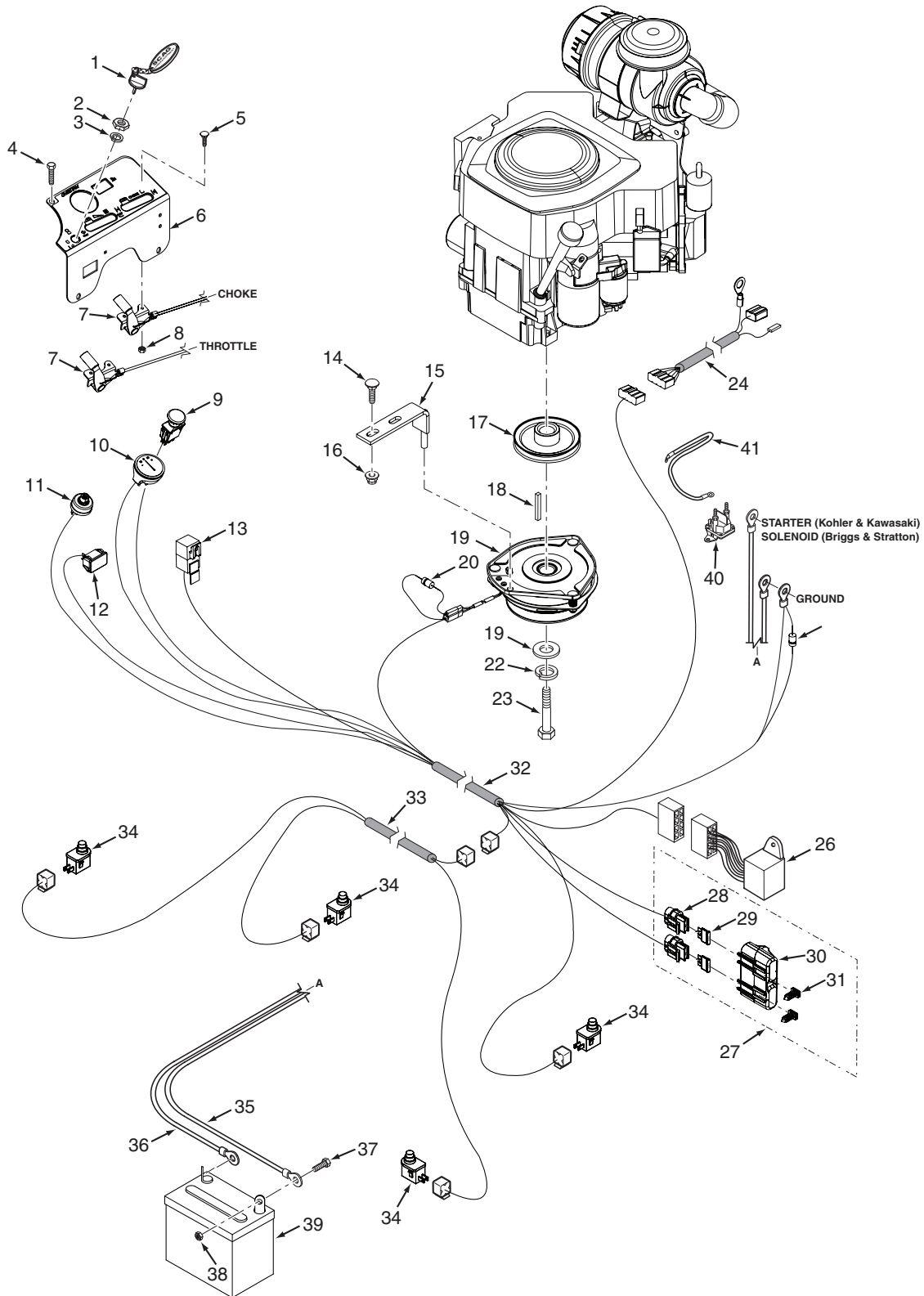

Section 8

SCZ ELECTRICAL SYSTEM (SEE SERIAL NUMBER RANGE BELOW)

Ref. No.	Part No.	Description
1	483366	Key, Ignition
	462069	Key Assembly w/Fob
2	48017-04	Nut, Hex 5/8-32
3	48017-03	Lockwasher, 5/8" Internal
4	04017-04	Bolt, Hex Head Serrated Flange 1/4-20 x 1/2"
5	04003-43	Bolt, Carriage #10-24 x 1/2"
6	462559	Instrument Panel w/Decal
7	481544	Control Cable
8	04021-26	Locknut, #10-24
9	483957	Switch, PTO
10	481755	Ammeter
11	48798	Switch, Starter
12	484565	Hourmeter
13	483013	Relay
14	04003-12	Bolt, Carriage 5/16-18 x 3/4"
15	452291	Anti-Rotation Weldment
16	04117-01	Nut, Flange Elastic Stop 5/16-18
17	484373	Pulley, 5" Dia. - 1.125 Bore
18	04063-28	Key, 1/4 x 1/4 x 3-1/2"
19	484276	Clutch, GT3.5 - 1.125 Bore
20	483958	Diode, 600V - 6A
21	04041-28	Flatwasher, 7/16-.469 x 1.75 x .25
22	04030-05	Lockwasher, 7/16" Spring
23	04102-03	Bolt, Hex Head 7/16-20 x 2-1/4" w/Patch
24	482543	Wire Harness Adapter, Kawasaki
	484078	Wire Harness Adapter, Kohler
	482836	Wire Harness Adapter, Briggs & Stratton
25	482253	Diode
26	483599	Electronic Module
27	483642	Double Fuse Assy. (incl. #28, 29, 30, 31)
28	483629	Fuse Holder
29	48298	Fuse, 20 Amp
30	483571	Cover, Sealed Double
31	482588	Clip, Wire
32	484563	Wire Harness, SCZ48/52
33	484562	Wire Harness, Operator Platform
34	481638	Switch
35	48029-13	Battery Cable, 25" Red (Kawasaki)
36	48029-11	Battery Cable, 27" Black
37	04001-44	Bolt, Hex Head 1/4-20 x 1/2"
38	04020-02	Nut, 1/4-20 UNC
39	*	Battery, 350 CCA
40	483278	Solenoid, Sealed (Briggs & Stratton)
41	48029-09	Battery Cable, Red 9" (Briggs & Stratton)

* Not available through Scag

Illustration for models produced in the following serial number range:		
SCZ48V-691FX	with a serial number of	H6700001 to H6700048
SCZ48V-25CV	with a serial number of	H6800001 to H6800999
SCZ48V-28BS	with a serial number of	H6900001 to H6900999
SCZ52V-730FX	with a serial number of	H7000001 to H7000999
SCZ52V-27CV	with a serial number of	H7100001 to H7100999
Always use the entire serial number listed on the serial number tag when referring to this product.		

SCZ ELECTRICAL SYSTEM (SEE SERIAL NUMBER RANGE ON THE NEXT PAGE)

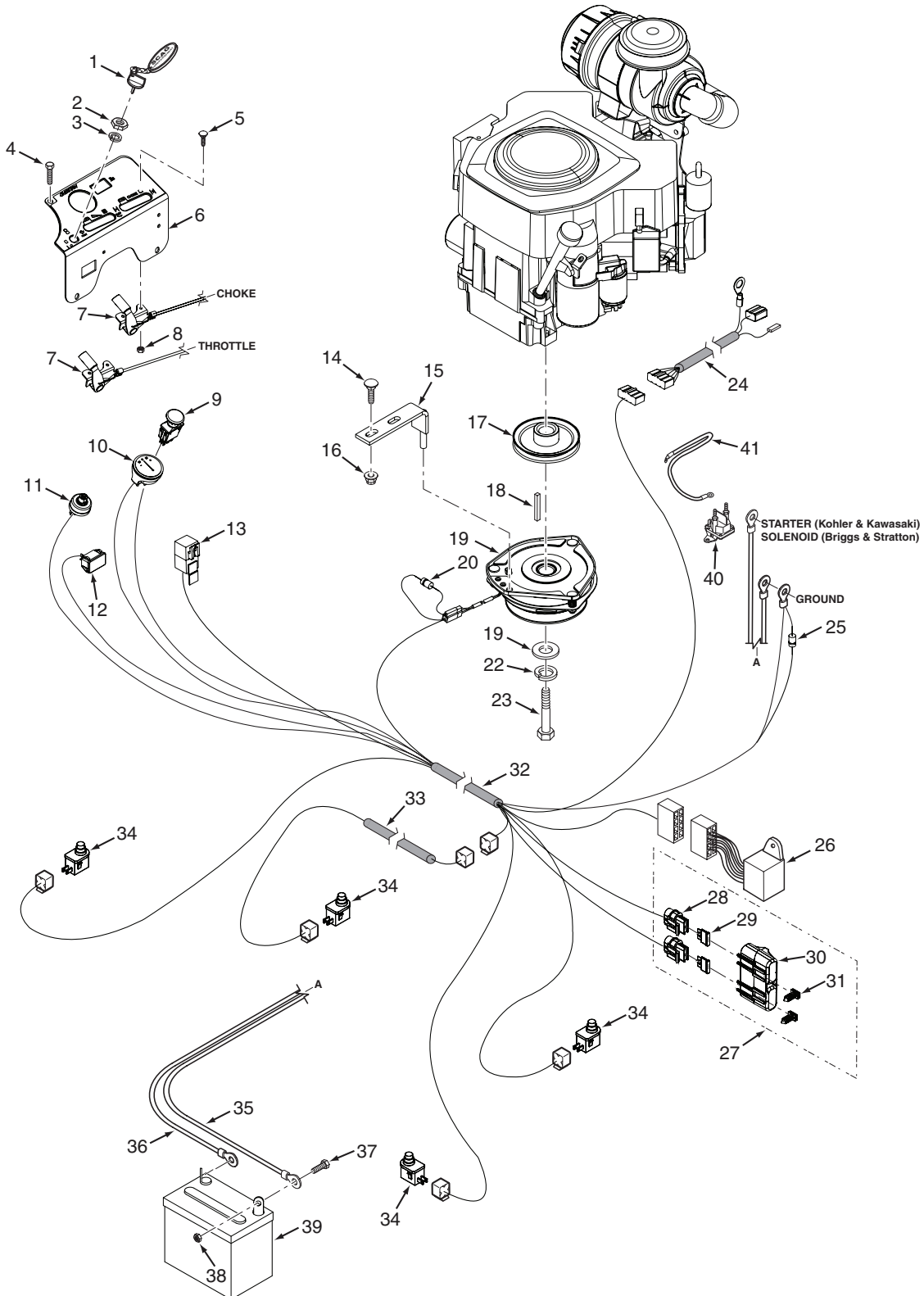

**SCZ ELECTRICAL SYSTEM
(SEE SERIAL NUMBER RANGE BELOW)**

Ref. No.	Part No.	Description
1	483366	Key, Ignition
	462069	Key Assembly w/Fob
2	48017-04	Nut, Hex 5/8-32
3	48017-03	Lockwasher, 5/8" Internal
4	04017-04	Bolt, Hex Head Serrated Flange 1/4-20 x 1/2"
5	04003-43	Bolt, Carriage #10-24 x 1/2"
6	462496	Instrument Panel w/Decal
7	481544	Control Cable
8	04021-26	Locknut, #10-24
9	483957	Switch, PTO
10	481755	Ammeter
11	48798	Switch, Starter
12	484565	Hourmeter
13	483013	Relay
14	04003-12	Bolt, Carriage 5/16-18 x 3/4"
15	452291	Anti-Rotation Weldment
16	04117-01	Nut, Flange Elastic Stop 5/16-18
17	484373	Pulley, 5" Dia. - 1.125 Bore
18	04063-28	Key, 1/4 x 1/4 x 3-1/2"
19	484276	Clutch, GT3.5 - 1.125 Bore
20	483958	Diode, 600V - 6A
21	04041-28	Flatwasher, 7/16-.469 x 1.75 x .25
22	04030-05	Lockwasher, 7/16" Spring
23	04102-03	Bolt, Hex Head 7/16-20 x 2-1/4" w/Patch
24	482543	Wire Harness Adapter, Kawasaki
	484078	Wire Harness Adapter, Kohler
	482836	Wire Harness Adapter, Briggs & Stratton
25	482253	Diode
26	483599	Electronic Module
27	483642	Double Fuse Assy. (incl. #28, 29, 30, 31)
28	483629	Fuse Holder
29	48298	Fuse, 20 Amp
30	483571	Cover, Sealed Double
31	482588	Clip, Wire
32	484723	Wire Harness, SCZ48/52
33	484722	Wire Harness, Operator Platform
34	481638	Switch
35	48029-13	Battery Cable, 25" Red (Kawasaki)
36	48029-11	Battery Cable, 27" Black
37	04001-44	Bolt, Hex Head 1/4-20 x 1/2"
38	04020-02	Nut, 1/4-20 UNC
39	*	Battery, 350 CCA
40	483278	Solenoid, Sealed (Briggs & Stratton)
41	48029-09	Battery Cable, Red 9" (Briggs & Stratton)

* Not available through Scag

Illustration for models produced in the following serial number range:		
SCZ48V-691FX	with a serial number of	H6700049 to H6799999
SCZ48V-25CV	with a serial number of	H6801000 to H6899999
SCZ48V-28BS	with a serial number of	H6901000 to H6999999
SCZ52V-730FX	with a serial number of	H7001000 to H7099999
SCZ52V-27CV	with a serial number of	H7101000 to H7199999
SCZ52V-28BS	with a serial number of	H7201000 to H7299999
Always use the entire serial number listed on the serial number tag when referring to this product.		

SCZ EFI ELECTRICAL SYSTEM

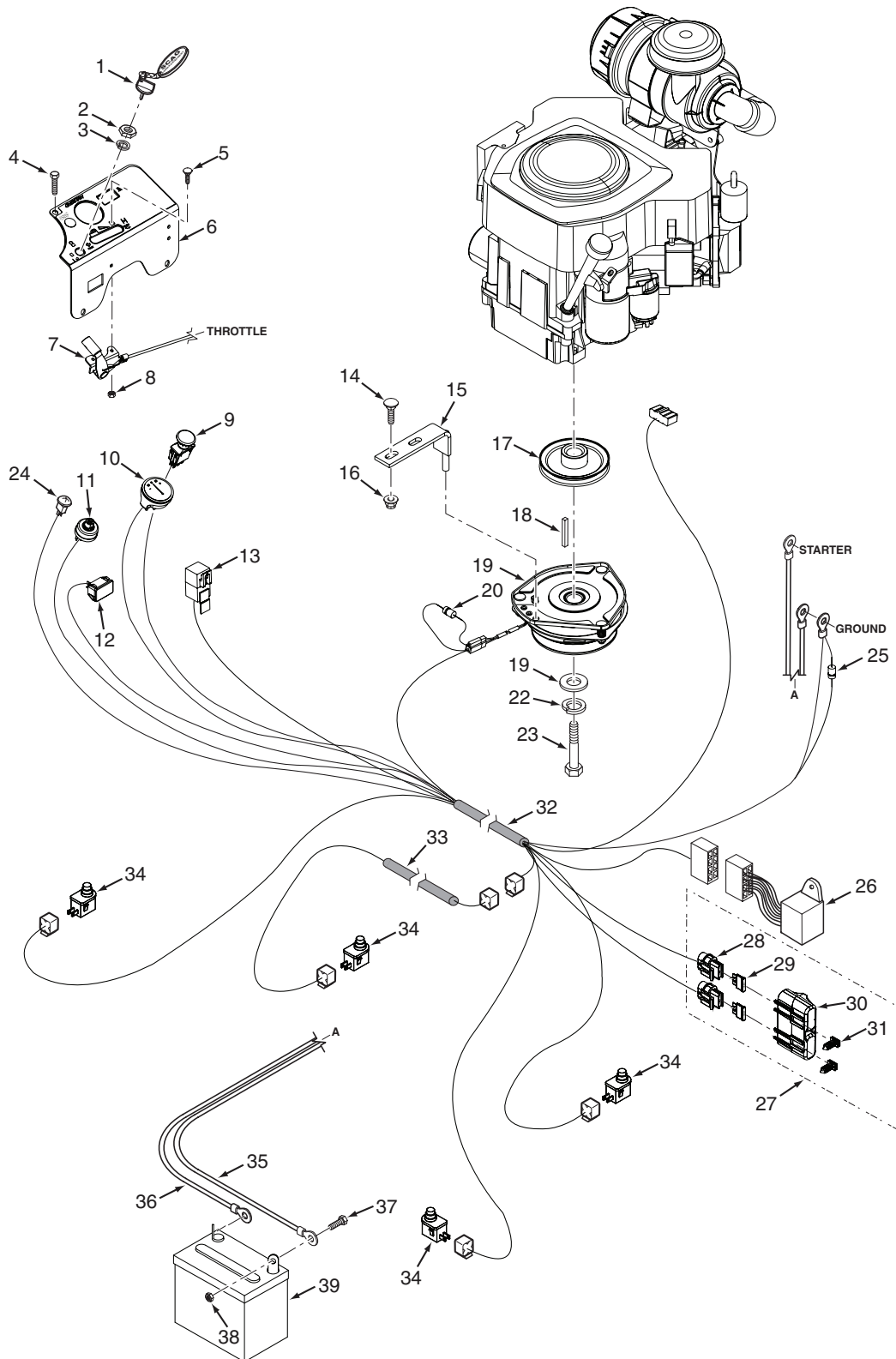

SCZ EFI ELECTRICAL SYSTEM

Ref. No.	Part No.	Description
1	483366 462069	Key, Ignition Key Assembly w/Fob
2	48017-04	Nut, Hex 5/8-32
3	48017-03	Lockwasher, 5/8" Internal
4	04017-04	Bolt, Hex Head Serrated Flange 1/4-20 x 1/2"
5	04003-43	Bolt, Carriage #10-24 x 1/2"
6	462XXX	Instrument Panel w/Decal
7	481544	Control Cable
8	04021-26	Locknut, #10-24
9	483957	Switch, PTO
10	481184	Voltmeter
11	48798	Switch, Starter
12	484565	Hourmeter
13	483013	Relay
14	04003-12	Bolt, Carriage 5/16-18 x 3/4"
15	452291	Anti-Rotation Weldment
16	04117-01	Nut, Flange Elastic Stop 5/16-18
17	484373	Pulley, 5" Dia. - 1.125 Bore
18	04063-28	Key, 1/4 x 1/4 x 3-1/2"
19	462339	Clutch, GT3.5 - 1.125 Bore
20	483958	Diode, 600V - 6A
21	04041-28	Flatwasher, 7/16-.469 x 1.75 x .25
22	04030-05	Lockwasher, 7/16" Spring
23	04102-03	Bolt, Hex Head 7/16-20 x 2-1/4" w/Patch
24	481182	Indicator Light
25	482253	Diode
26	483599	Electronic Module
27	483642	Double Fuse Assy. (incl. #28, 29, 30, 31)
28	483629	Fuse Holder
29	48298	Fuse, 20 Amp
30	483571	Cover, Sealed Double
31	482588	Clip, Wire
32	484726	Wire Harness, SCZ-EFI
33	484722	Wire Harness, Operator Platform
34	481638	Switch
35	48029-13	Battery Cable, 25" Red (Kawasaki)
36	48029-11	Battery Cable, 27" Black
37	04001-44	Bolt, Hex Head 1/4-20 x 1/2"
38	04020-02	Nut, 1/4-20 UNC
39	*	Battery, 350 CCA

* Not available through Scag

REPLACEMENT DECALS AND INFORMATION PLATES



1

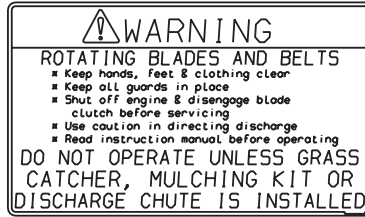

2

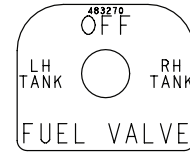

10

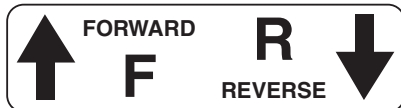

6



3



9



8



11

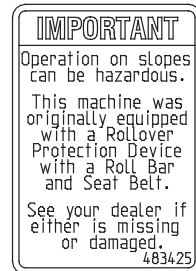

5

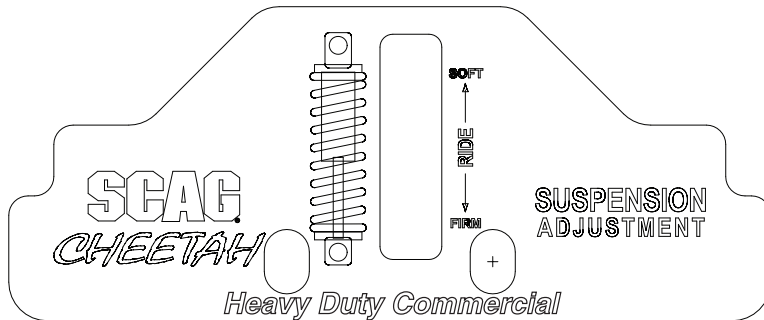

12



13



14

REPLACEMENT DECALS AND INFORMATION PLATES

Ref. No.	Part No.	Description
1	483407	Decal, Spinning Blades
2	483406	Decal, Knives
3	483199	Decal, 48" Velocity Plus
	483200	Decal, 52" Velocity Plus
4	483633	Decal, Seat Replacement
5	483425	Decal, ROPS
6	482100	Decal, Traction Control
7	483405	Decal, Warning
8	48404	Decal, Made in USA
9	483402	Decal, Belt Cover
10	483270	Decal, Fuel Shut Off
11	484126	Decal, Scag Cheetah
	484694	Decal, Scag Cheetah - Electronic Fuel Injection (not shown)
12	484127	Decal, Suspension Adjustment
13	484134	Decal, Deck Height - LH
14	484135	Decal, Deck Height - RH
15	484564	Decal, Instrument Panel - SCZ
	484613	Decal, Instrument Panel - SCZ-EFI (not shown)
16	484520	Decal, Cheetah
17	484180	Decal, Start / Drive
18	484244	Decal, Adjustments - SCZ
19	483425	Decal, ROPS
**	462373	Spanish Decal Kit, SCZ (not shown)
	01411	DVD Video, Tips for Safe Operation of Your Scag Zero-Turn Mower

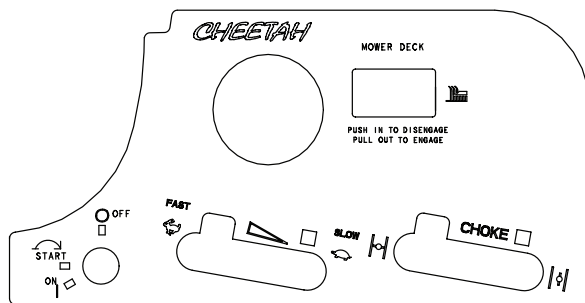

15



7

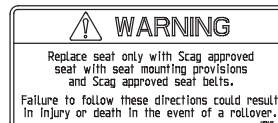

4

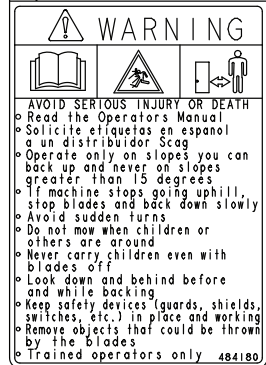
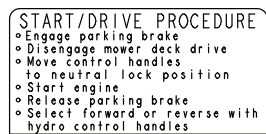

17

IMPORTANT ADJUSTMENT PROCEDURES:
READ OPERATORS MANUAL FOR MORE DETAILS

Check tire pressure - Drive tires-8 psi -
- Caster tires-FlatFree

FREE WHEEL OPERATION
To move machine without running engine, turn valve on LH & RH transaxles from RUN to BY-PASS. (see operator's manual)

NEUTRAL ADJUSTMENT

To re-set neutral, have engine off and control levers in neutral. Loosen upper linkage hex nuts. Allow transmission to position linkage cable and tighten upper hex nuts. Repeat for opposite side. If wheels still creep after adjustment, see an authorized Scag dealer.

HYDRAULIC FLUID LEVEL
Check hydraulic fluid level while fluid is cool. Fluid level should be in sight window as shown. Fill with 20W50 motor oil only.

IMPORTANT
Do not overfill. Room for hot fluid expansion must be allowed or resulting expansion may cause leaks in the system

TRACKING ADJUSTMENT

If machine pulls to right, adjust LH control stop bolt CW (inward) to slow left wheel down.
If machine pulls to left, adjust RH control stop bolt CW (inward) to slow right wheel down.

484244

18



16

SCZ ELECTRICAL SCHEMATIC (SEE PAGE 73 FOR SERIAL NUMBER RANGE)

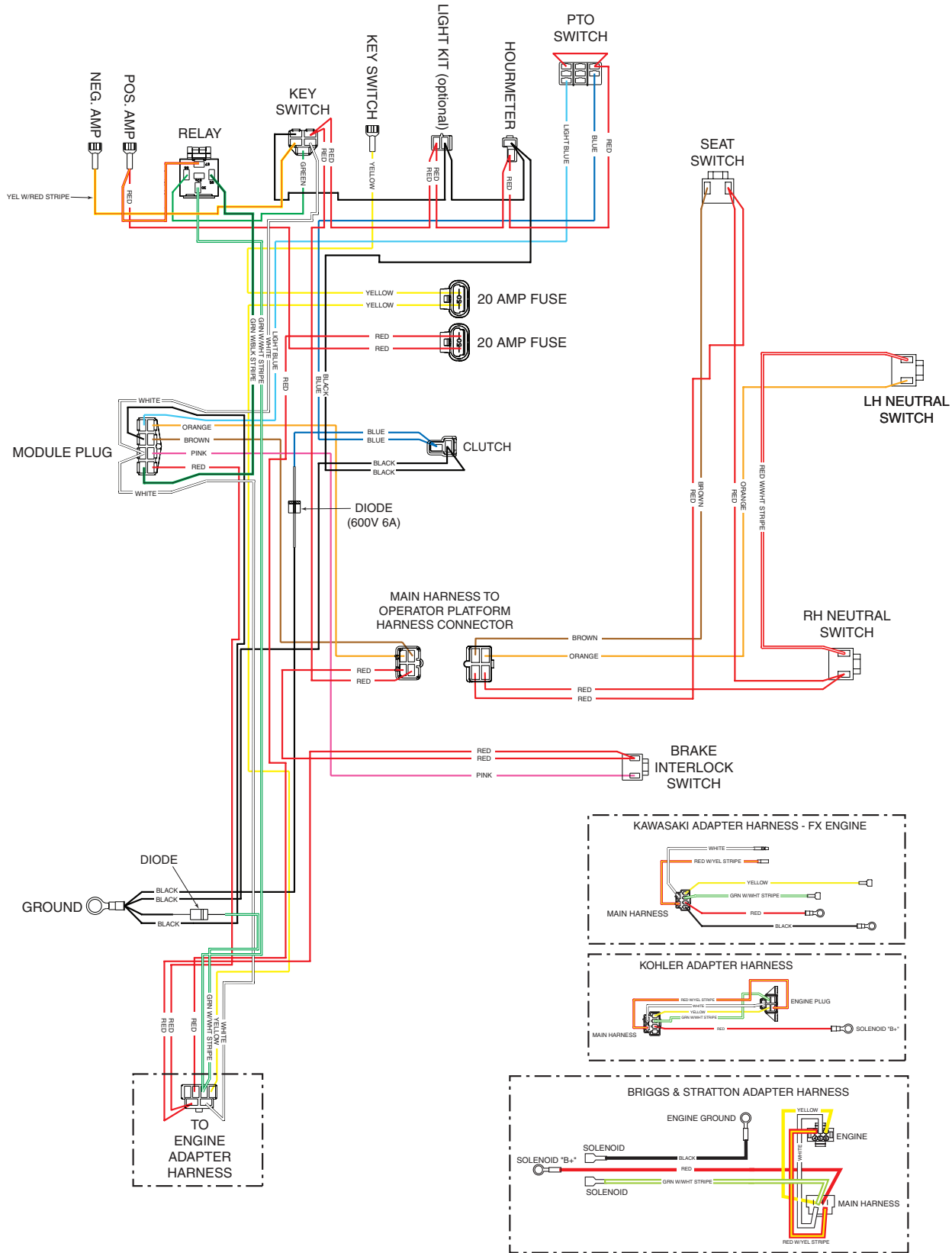

SCZ ELECTRICAL SCHEMATIC (SEE PAGE 75 FOR SERIAL NUMBER RANGE)

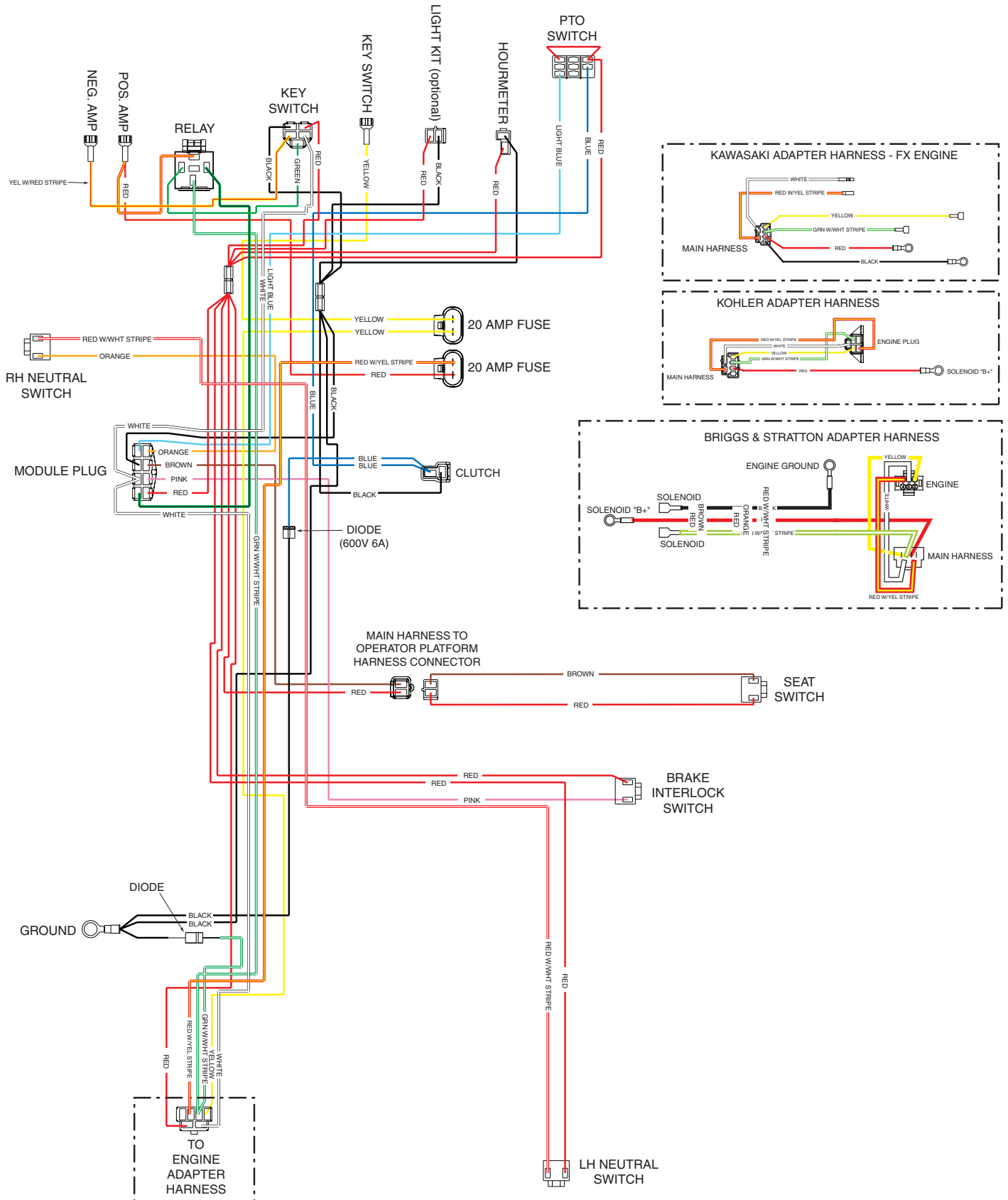

SCZ EFI ELECTRICAL SCHEMATIC

